



BUTTERFLY VALVE

VBG12121- 300PSI Grooved-End Butterfly Valve

- Approved Gear Operator for both Indoor or Outdoor use
- NSF Certified Epoxy Coated Ductile Iron body for Excellent Protection
- Elastomer Encapsulated Disc with Outstanding Flow Characteristics
- Extended Neck
- Low Torque Operation
- Options of Double Internal Supervisory Switches
- FM Approved & UL/ULC Listed

Material Specifications

PART	SPECIFICATION
1. Upper Stem	Stainless Steel ASTM A 276 Type 420
2. Upper Bearing	PTFE Bronze Sintered on Steel
3. O-Ring	EPDM
4. Body	Ductile Iron ASTM A 395, Epoxy Coated
5. Disc	Ductile Iron ASTM A 395 with EPDM Encapsulation
6. Lower Bearing	PTFE Bronze Sintered on Steel
7. Lower Stem	Stainless Steel ASTM A 276 Type 420
8. Dust Plug	PVC
9. Name Plate	Stainless Steel
10. Gear Operator	Cast Iron and Steel
11. Indicator Flag	Steel
12. Handwheel	Cast Iron
13. Cable gland	Nylon

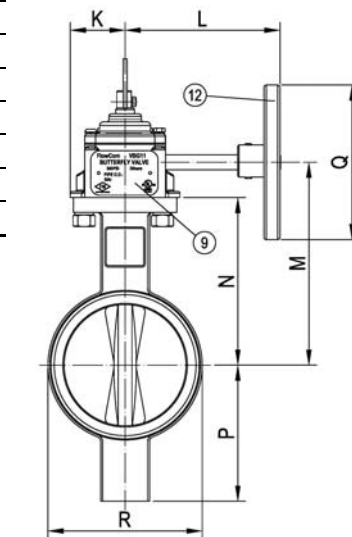
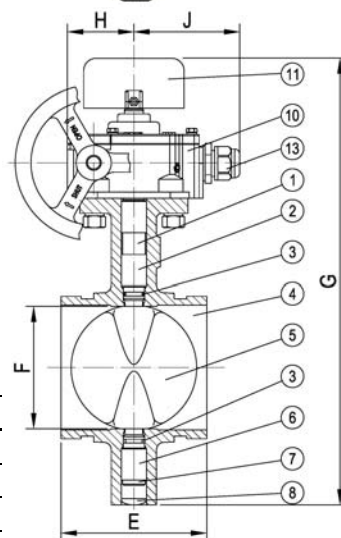

Dimension

Part Number	Size		OD	E		F		G		H		J		K	
	in.	mm		in.	mm	in.	mm	in.	mm	in.	mm	in.	mm	in.	mm
VBG12121-060	2	50	60.3	3.19	81	2.01	51	9.92	252	2.09	53	3.35	85	1.73	44
VBG12121-073	2 1/2	65	73.0	3.85	98	2.40	61	11.22	285	2.09	53	3.35	85	1.73	44
VBG12121-076	3OD	65	76.1	3.85	98	2.40	61	11.22	285	2.09	53	3.35	85	1.73	44
VBG12121-089	3	80	88.9	3.85	98	2.87	73	12.20	310	2.09	53	3.35	85	1.73	44
VBG12121-114	4	100	114.3	4.56	116	3.86	98	14.17	360	2.09	53	3.35	85	1.73	44
VBG12121-140	5 1/2 OD	125	139.7	5.86	149	4.80	122	15.35	390	2.99	76	3.35	92	1.85	47
VBG12121-141	5	125	141.3	5.86	149	4.80	122	15.35	390	2.99	76	3.62	92	1.85	47
VBG12121-165	6 1/2 OD	150	165.1	5.86	149	5.75	146	16.73	425	2.99	76	3.62	92	1.85	47
VBG12121-168	6	150	168.3	5.86	149	5.75	146	16.73	425	2.99	76	3.62	92	1.85	47
VBG12121-219	8	200	219.1	5.27	134	7.72	196	19.41	493	2.99	76	3.62	92	1.85	47
VBG12121-273	10	250	273.0	6.30	160	9.57	243	22.76	578	3.74	95	3.94	100	2.60	66

Size	L		M		N		P		Q		R		Wt.	
	in.	mm	in.	mm	in.	mm	in.	mm	in.	mm	in.	mm	lbs.	kg.
2	4.92	125	4.25	108	3.15	80	2.36	60	4.25	108	2.59	66	8.8	4.0
2 1/2	4.92	125	4.92	125	3.78	96	2.95	75	4.25	108	3.35	85	10.8	4.9
3OD	4.92	125	4.92	125	3.78	96	2.95	75	4.25	108	3.35	85	11.0	5.0
3	4.92	125	5.28	134	4.13	105	3.54	90	4.25	108	3.82	97	12.3	5.6
4	4.92	125	6.46	164	5.31	135	4.33	110	4.92	125	4.88	124	17.3	7.9
5 1/2 OD	6.62	168	7.17	182	5.83	148	5.00	127	5.90	150	6.10	155	29.8	13.5
5	6.62	168	7.17	182	5.83	148	5.00	127	5.90	150	6.10	155	29.8	13.5
6 1/2 OD	6.62	168	7.83	199	6.50	165	5.71	145	5.90	150	7.20	183	34.0	15.4
6	6.62	168	7.83	199	6.50	165	5.71	145	5.90	150	7.20	183	33.1	15.0
8	6.62	168	9.37	238	8.03	204	6.89	175	5.90	150	9.29	236	45.0	20.4
10	9.45	240	11.18	284	9.65	245	8.27	210	9.84	250	11.38	289	79.7	36.2



BUTTERFLY VALVE



Butterfly Valve Performance Date

Formulas for C_v Values

$$\Delta P = \frac{Q^2}{C_v^2}$$

Where: Q = Flow rate (gallons per minute: GPM)

ΔP = Pressure drop across valve (PSI)

$$Q = C_v \times \sqrt{\Delta P}$$

C_v = Flow coefficient

Nominal Size	Pipe O.D.	Cv (Full Open)	Nominal Size	Pipe O.D.	Cv (Full Open)	Nominal Size	Pipe O.D.	Cv (Full Open)
2 in.	50 mm	60.3	4 in.	100 mm	114.3	6 in.	150 mm	168.3
2½ in.	65 mm	73.0	5½ OD	125 mm	139.7	8 in.	200 mm	219.1
3 OD	65 mm	76.1	5 in.	125 mm	141.3	10 in.	250 mm	273.0
3 in.	80 mm	88.9	6½ OD	150 mm	165.1			

