

TECHNICAL DATA SHEET

for use by Architects & Engineers

Pendent and Upright Sprinklers

Model No: LF211, LF221, LF210 and LF220



Features

- Glass bulb
- Standard Spray Pattern
- K-factor 5.6
- Quick & Standard Response

Description

The 1/2 inch orifice LIFECO Standard and Quick Response (ref. ISO 6182) Pendent and Upright Sprinklers are automatic sprinklers of the frangible bulb type. They are "Standard and Quick response orifice spray Sprinklers" intended for use in fire Sprinkler systems designed in accordance with the Standard installation (NFPA 13). The pendent and upright sprinklers all produce a hemi-spherical water distribution pattern below the deflector. It is most stable against the change of atmospheric temperature and is well matched to accommodate any architecture.

The 1/2 inch orifice LIFECO Standard and Quick Response Pendent and Upright are rated for use at a maximum service pressure of 12.3 kg/cm² (175psi) and they are available in the temperature ratings of 68°C (155°F, Red) and 93°C (200°F, Green). The flow rates "Q" in LPM (GPM) are determined by the following formula: $Q = K \sqrt{P}$

Where the nominal discharge coefficient "K" equals 80 (5.6); and, "P" equals the residual flowing pressure in kgf/cm² (psi). Listing standards permit the actual value of "K" to vary from 76.4 to 83.6 (5.3 to 5.8); however, for hydraulic calculations, a K-factor of 80 (5.6) is to be applied.

The Frame is made of brass forging (copper alloy) per KS D5101. The bulb cap (bulb retainer) is copper alloy per KS D5102 (C5191).

The Spring Seat consists of a Beryllium Nickel disc spring that is sealed on both its inside and outside faces with a Teflon gasket.

The Compression Screw is copper alloy per KS D5101 (C3604) and the Deflector is copper alloy per KS D5201 (C2200). The model LF210 and LF220 series, Sprinklers utilize a 5mm diameter frangible bulb made by JOB. The model LF211 and LF221 series, Sprinklers utilize a 3mm diameter frangible bulb made by JOB. The Frame and Deflector of this sprinkler are Nickel Chrome plated. The bulb liquid color is red and green in accordance with the temperature ratings.

Technical & Environmental Specification

Minimum Operating Pressure	7 psi (0.5 bar)
Maximum Working Pressure	175 psi (12 bar)
Discharge Coefficient	$K = 5.6 \text{ GPM/psi}^{1/2} (80.7 \text{ LPM/bar}^{1/2})$
Temperature Rating	135 / 155 / 200 F (57 / 68 / 93 °C)
Leakage Test at Factory	30Kgf/cm ² (0.3Mpa, 29.4bar, 426.7 psi)

Materials

Frame Forging	Brass AS1568 Alloy486
Deflector	Copper C2200
Spring Seat	Ni-Be alloy, coated on both sides with Teflon Tape
Bulb	Glass
Bulb Cap	Phosphor Bronze C5191
Screw	Brass C3604

Installation

The LIFECO sprinklers are intended for fire protection systems designed in accordance with the standard installation rules of the applicable listings or approval agency. (eg., NFPA 13 or FM's Loss Prevention Data Sheets)

Note:

Do not install any bulb type sprinkler if the bulb is cracked or there is a loss of fluid from the bulb. And with the sprinkler held horizontally, a small air bubble should be present. The sprinkler joint should be obtained with maximum torque of 28.5 Nm (21 ft-lbs)

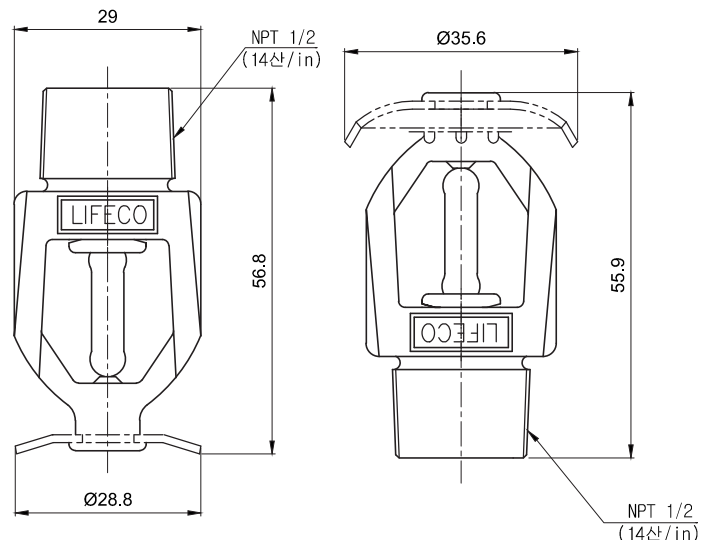

TECHNICAL DATA SHEET

for use by Architects & Engineers

Pendent and Upright Sprinklers

Model No: LF211, LF221, LF210 and LF220



Sectional Detail

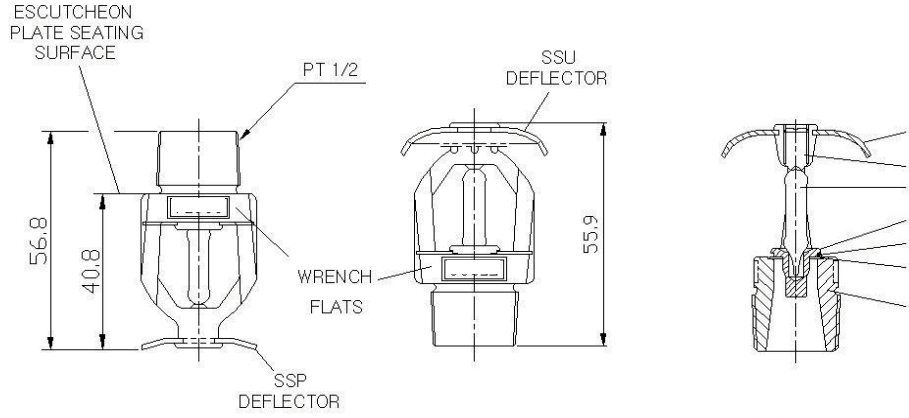

PENDENT

UPRIGHT

CROSS SECTION

- | | | | |
|-----------|-----------------|----------------|--------------|
| 1 - FRAME | 2 - SPRING SEAT | 3 - GLASS BULB | 4 - BULB CAP |
| 5 - SCREW | 6 - DEFLECTOR | 7 - SPRING | |

Installation Detail

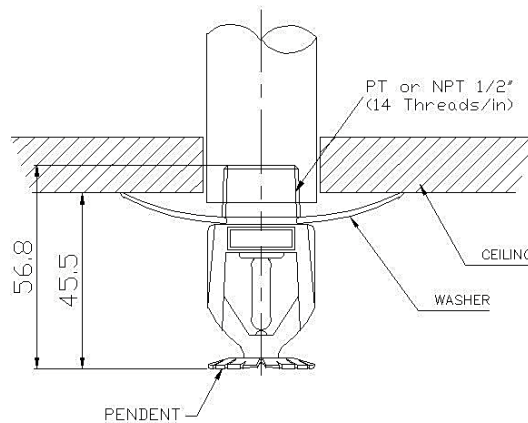

Water Spray Pattern

