

1 For your safety

1.1 General safety statements

- Before using this product, carefully read the Instructions for Use.
- Strictly follow the Instructions for Use. The user must fully understand and strictly observe the instructions. Use the product only for the purposes specified in the Intended Use section of this document.
- Do not dispose of the Instructions for Use. Ensure that they are retained and appropriately used by the product user.
- Only fully trained and competent users are permitted to use this product.
- Comply with all local and national rules and regulations associated with this product.
- Only trained and competent personnel are permitted to inspect, repair and service the product. Dräger recommends a Dräger service contract for all maintenance activities and that all repairs are carried out by Dräger.
- Properly trained service personnel must inspect and service this product as detailed in the Maintenance section of this document.
- Use only genuine Dräger spare parts and accessories, or the proper functioning of the product may be impaired.
- Do not use a faulty or incomplete product, and do not modify the product.
- Notify Dräger in the event of any component fault or failure.
- All approved respiratory equipment shall be selected, fitted, used, and maintained in accordance with MSHA (Mine Safety and Health Administration), OSHA (Occupational Safety and Health Administration), and other applicable regulations.
- Do not use any form of chemical marking or paint on the equipment.
- The air supply shall meet the requirements for breathing air according to CGA G-7.1, Grade D or higher quality.
- Before occupational use of this respirator a written respiratory protection program must be implemented meeting all the local government requirements. In the United States employers must comply with OSHA 29 CFR 1910.134 which includes medical evaluation, training, and fit testing.

1.2 Definitions of alert icons

Alert icons are used in this document to provide and highlight text that requires a greater awareness by the user. A definition of the meaning of each icon is as follows:

WARNING
Indicates a potentially hazardous situation which, if not avoided, could result in death or serious injury.

CAUTION
Indicates a potentially hazardous situation which, if not avoided, could result in physical injury or damage to the product or environment. It may also be used to alert against unsafe practices.

NOTICE
Indicates additional information on how to use the product.

2 Description

2.1 Product overview

The Dräger PSS® 3000 Series is a self contained breathing apparatus (SCBA) that provides the wearer with respiratory protection using an open-circuit, pressure-demand, compressed-air system. The apparatus can be used as a self-contained system, or with an independent air supply for supplied-air respirator (SAR) operations. The series is compatible with a wide range of compressed-air cylinders, face masks and lung demand regulators (e.g. FPS 7000 and Panorama Nova face masks, Dräger lung demand regulators, and aluminum or composite cylinders).

2.2 Feature description

The carrying system uses a lightweight polymer-composite space frame (Fig 1, Item 3). The shoulder straps and waist belt are fully adjustable and use webbing harness straps and moulded padding on the shoulder pads and waist pad.

The apparatus uses the Dräger high-performance first-stage regulator (6) that reduces cylinder pressure and supplies breathing air through a medium-pressure hose (5) and coupling (1) to an attached lung demand regulator. The apparatus is fitted with a mechanical pressure gauge (4) that incorporates an end-of-service time (EOST) whistle that sounds to warn the wearer that there is low cylinder pressure (see Section 8 for the EOST activation pressures). A dual-pressure hose (7) supplies air to the whistle when it is activated, and has an internal capillary tube that supplies high-pressure air from the cylinder to the gauge.

The air hoses and the first-stage regulator are integrated into the space frame to prevent snagging and enhance component protection. The hose clips (2) hold the air hoses in position on the shoulder straps.

Breathing apparatus serial number

The breathing apparatus serial number is on the first-stage regulator.

Compressed-air cylinders, lung demand regulators and face masks

The Dräger PSS 3000 Series is compatible with a single aluminum or composite material cylinder of 30 to 60 minute capacity, and is available in 2216 psi or 4500 psi versions. Full descriptions and user instructions are contained in separate instructions supplied with the cylinder, face mask or lung demand regulator.

2.3 Intended use

The PSS 3000 Series breathing apparatus, when fitted with a cylinder, lung demand regulator and face mask, is intended for use in applications where a high level of respiratory protection is required. The assembled breathing apparatus provides the wearer with respiratory protection for working in contaminated or oxygen-deficient conditions.

The cylinder, lung demand regulator, face mask and other accessories used with this product must be certified Dräger components, assembled in an approved configuration, otherwise the operation of the device may be impaired. Contact Dräger for further information.

2.3.1 Limitation

This product is not approved to provide protection from military grade chemical, biological, radiological, and nuclear hazards (CBRN). Do not attempt to use the product for respiratory protection in CBRN environments.

2.4 Approvals

The Dräger PSS 3000 Series is certified by NIOSH. The apparatus must only be used in conjunction with compressed-air cylinders approved by NIOSH.

2.5 Explanation of marking and symbols

Refer to the relevant authority for explanation of approval body symbols and marking on the equipment. Examples of other marking on component parts of the breathing apparatus are:

BRAC-1359	–	Dräger serial number
08/09	–	Month and year of manufacture
3356812 or R21034	–	Dräger part number
SF	–	Standard force coupling
LF	–	Low force coupling

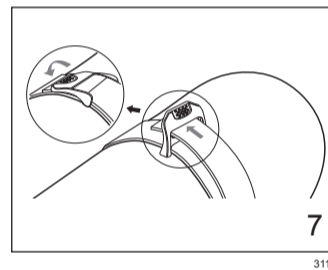
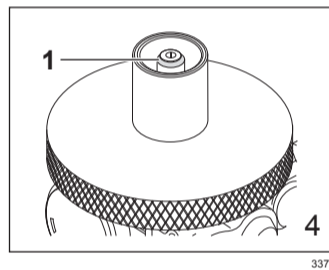
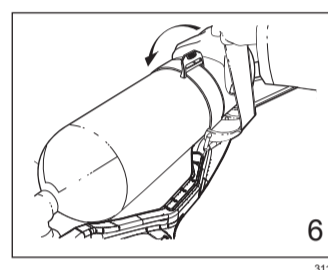
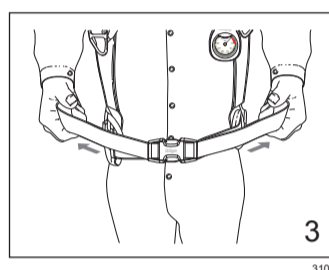
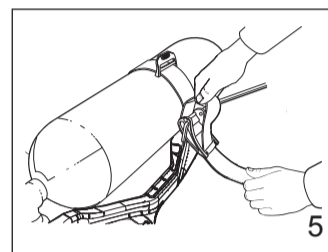
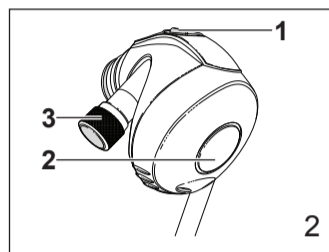
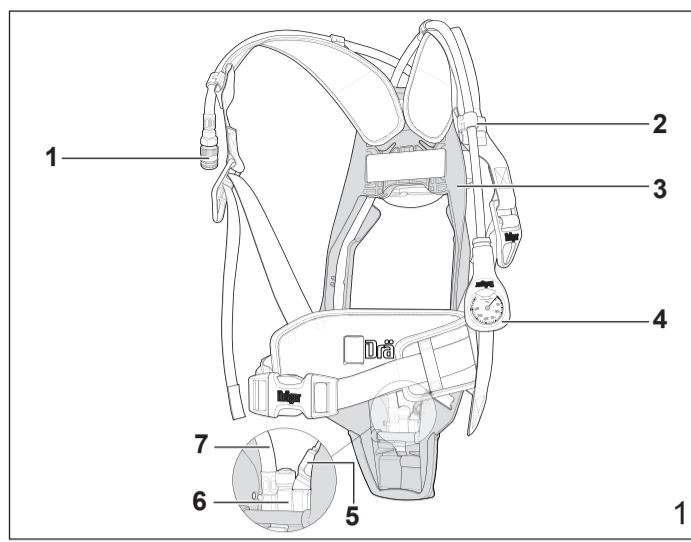

3 Use

WARNING
Only trained and competent personnel should prepare and use breathing apparatus. Ensure that any accessories, ancillary equipment and other protective clothing items do not interfere with the apparatus and do not create a safety hazard.

The effective working duration of the apparatus is dependent on the initial air supply available and the breathing rate of the wearer. Fill air cylinders to their full rated pressure prior to use, and do not commence any operation (including supplied-air respirator (SAR) operations) using a cylinder that is less than 90 percent full.

CAUTION
Do not apply excessive force or use tools to open or close a cylinder valve, and do not drop or throw down the breathing apparatus.

Refer to the following additional information before preparing or using the breathing apparatus:

- The special instructions (see Section 9).
- The NIOSH Approval Label 3359026 for approved configurations.

3.1 Preparation for use

NOTICE
The face of the pressure gauge may be fitted with a thin flexible protective covering. Remove this covering before first use.

1. Carry out a visual inspection of the breathing apparatus (see Section 3.5.1).
2. Fit the air cylinder (see Section 3.5.2).
3. Press the male coupling of the lung demand regulator hose into the female coupling of the medium-pressure hose until an audible click is heard (do not connect the regulator to the face mask at this stage).
4. Press the reset button (Fig 2, Item 1) to switch off the positive pressure. Press and rotate the bypass button (Fig 2, Item 3) to align the red spots and then release the button to switch off the bypass.
5. Carry out a full functional test of the apparatus (see Section 3.5.3).
6. Align and push the lung demand regulator into face mask port until it latches in position, and check the attachment by gently attempting to pull the coupling apart.

3.2 Putting on the breathing apparatus

1. Fully loosen the shoulder straps and waist belt and put on the breathing apparatus.
2. Check that the shoulder pads are not twisted and take the weight of the system on the shoulders by pulling the shoulder straps. Do not fully tighten at this stage.
3. Close the waist belt buckle and pull the ends of the waist belt until it fits securely and comfortably (Fig 3). Tuck the belt ends behind the waist pad or belt.
4. Pull the shoulder straps until the breathing apparatus rests securely and comfortably on the hips. Do not over tighten. Tuck the belt ends behind the waist pad or belt.
5. Fully loosen the head straps of the face mask and place the neck strap over the back of the neck.
6. Press the reset button (Fig 2, Item 1) to switch off the positive pressure.
7. Open the cylinder valve (counterclockwise) slowly, but fully, to pressurize the system.

NOTICE
After storage at temperatures below 32 °F (0 °C) leakage may be observed when the cylinder valve is initially opened due to ice formation.

- If leakage is observed from the **lung demand regulator**: Press the front button (Fig 2, Item 2) to allow a rush of air to pass through the lung demand regulator and then quickly press the reset button (Fig 2, Item 1) to switch off the positive pressure. Resume normal operation.
- If leakage is observed from the **quick connect cylinder coupling**: Close the cylinder valve and vent the system. Disconnect then reconnect the cylinder to the breathing apparatus, then reopen the cylinder valve slowly, but fully, to pressurize the system. Resume normal operation.
- In the event that leakage still occurs, remove the breathing apparatus from service and report the fault to trained service personnel or contact Dräger.

8. Put on the face mask and check for tight fit (see the Instructions for Use supplied with the face mask).

3.3 During use

WARNING
Fully open the cylinder valve and ensure it remains open during use.

Users should be in a safe area before the end-of-service time (EOST) whistle warning commences. Evacuate to a safe area immediately if the warning commences during an operation.

Using the bypass button (Fig 2, Item 3) will use air from the cylinder and rapidly reduce the working duration of the apparatus.

- Regularly check the remaining cylinder pressure on the gauge.
- If additional air is required, briefly press and release the bypass button (Fig 2, Item 3) to deliver a single jet of air into the face mask.

WARNING
The emergency air flow procedures below may greatly reduce the operating duration of the air supply. When activated the user must immediately evacuate to a safe area. The reason for using the procedure must be investigated and repaired before reusing the apparatus.

- Additional air flow required (emergency procedure only used in the unlikely condition of low or blocked airflow) – Press and rotate the bypass button (Fig 2, Item 3) to deliver a sustained air supply (85 to 130 liters/minute) into the face mask.
- Excessive or loss of air flow (emergency procedure only used in the unlikely condition of high or loss of airflow) – Close the cylinder valve then immediately begin to slowly reopen the valve. Use the cylinder valve as a regulating valve to set the air flow to meet the user requirement. This procedure can be used with screw-type and ratchet-type cylinder valves.

3.4 After use

WARNING
Do not remove the breathing apparatus until in a safe breathing environment.

1. Loosen the face mask straps. As the seal between the face mask and the face is broken, press the reset button (Fig 2, Item 1) to switch off the positive pressure. Fully remove the face mask and extend all of the straps of the head harness.
2. Close the cylinder valve.
3. Press the front button (Fig 2, Item 2) to vent system and then press the reset button (Fig 2, Item 1) to switch off the positive pressure.
4. Release the waist belt buckle.
5. Lift the shoulder strap buckles to loosen the straps.
6. Remove the breathing apparatus and face mask.
7. Carry out the after use tasks in the maintenance table (see Section 5.1).
8. Remove the air cylinder if required (see Section 3.5.2).
9. Pass the breathing apparatus to the service department with details of any faults or damage that occurred during use.

3.5 Common user tasks

3.5.1 Visual inspection

A visual inspection must check the full breathing apparatus including all component parts and accessories. Check that the equipment is clean and undamaged, paying particular attention to pneumatic components, hoses and connectors. Typical signs of damage that may affect the operation of the breathing apparatus include impact, abrasion, cutting, corrosion and discoloration. Report damage to service personnel and do not use the apparatus until faults are rectified.

3.5.2 Air cylinder fitting and removing

WARNING
High-pressure air release may cause injury to the user or other personnel near the breathing apparatus. Close the cylinder valve and fully vent the system before attempting to disconnect an air cylinder.

Impact damage to the cylinder valve or first-stage regulator connector may prevent valve connection or cause an air leak. Handle the air cylinder and breathing apparatus with care.

NOTICE
The following instructions are for a CGA-type threaded cylinder coupling. For other cylinder connector types, refer to the Instructions for Use supplied with the connector.

Fitting the cylinder

1. Check the threads of the cylinder valve port and the first-stage regulator. Ensure that the O-ring seal (Fig 4, Item 1) in the regulator is clean and undamaged.
2. Lay the apparatus horizontal, with the regulator uppermost, and fully extend the cylinder strap.
3. Insert the cylinder through the loop of the strap, and align the valve with the regulator.
4. Lift the cylinder and space frame into the vertical position (supported on the end of the cylinder opposite the valve).
5. Tighten the hand wheel of the regulator, using only the thumb and index finger, until a definite metal-to-metal contact is felt. Do not use tools or over tighten.
6. Place the unit back into the horizontal position.
7. Take up the slack in the cylinder strap (Fig 5).
8. Pull the strap over the cylinder to operate the cam lock (Fig 6).
9. Secure the strap end using the cylinder strap retainer (Fig 7). Release the cam lock to adjust the position of the cylinder strap retainer if necessary.

Removing the cylinder

1. Close the cylinder valve and press the front button (Fig 2, Item 2) to fully vent the system.
2. Lay the apparatus horizontal, with the cylinder uppermost.
3. Lift the cylinder strap retainer.
4. Lift the strap against the cam lock to release the buckle tension, and then loosen the strap.
5. Disconnect the cylinder valve from the first-stage regulator.
6. Lift the cylinder away from the regulator and remove the cylinder.

3.5.3 Functional testing

WARNING
Failure of the breathing apparatus to meet any of the standards or parameters described in the functional tests indicates a system fault. Report the fault to trained service personnel or contact Dräger. Do not use the breathing apparatus until the fault condition is rectified.

Assemble the breathing apparatus as described in the preparation for use (see Section 3.1) before commencing any functional testing.

Leak test and whistle warning test

1. Press the reset button (Fig 2, Item 1) to switch off the positive pressure. Press and rotate the bypass button (Fig 2, Item 3) to align the red spots and then release the button to switch off the bypass.
2. Open the cylinder valve (counterclockwise) slowly, but fully, to pressurize system. During pressurization a momentary sounding of the whistle will occur.
3. Fully close the cylinder valve.
4. After one minute, check the contents gauge and then reopen the cylinder valve. The gauge must not show an increase in pressure of more than 200 psi. If the pressure increase is more than 200 psi, investigate and repair the fault (see Section 4), and then repeat the leak test.
5. Fully close the cylinder valve.
6. Cover the outlet port of the lung demand regulator with the palm of the hand and press the front button (Fig 2, Item 2) to switch on the positive pressure.
7. Carefully lift the palm of the hand to slowly vent the system until the whistle activates, and observe the pressure displayed on the gauge.
8. The whistle must begin to sound in the range:
2216 psi cylinder: 600 psi to 510 psi
4500 psi cylinder: 1215 psi to 1035 psi
9. Continue to vent the system until fully exhausted.
10. Press the reset button (Fig 2, Item 1) to switch off the positive pressure.



4 Troubleshooting

The troubleshooting guide shows fault diagnosis and repair information applicable to breathing apparatus users. Further troubleshooting and repair information is available in Instructions for Use supplied with associated equipment.

Where the troubleshooting guide shows more than one fault or remedy, carry out repair actions in the order that they appear in the table.

Contact service personnel or Dräger when the remedy information indicates a service task, or if the symptom remains after all remedy actions have been attempted.

Symptom	Fault	Remedy
Face mask air leak	Lung demand regulator O-ring leaking Head straps not tight Exhalation valve leaking Speech diaphragm defective	Renew or lubricate O-ring Tighten Service task Service task
Unsatisfactory communication	Speech diaphragm defective	Service task
High-pressure air leak or failed leak test	Loose or dirty connector Faulty hose or component	Disconnect, clean and reconnect couplings and retest Substitute user replaceable accessories and retest
Air leak from medium-pressure hose connection at the first-stage regulator (safety relief valve)	Faulty O-ring, retainer, spring or first-stage regulator	Service task
Lung demand regulator allowing constant air flow into the face mask	Bypass button engaged Internal fault	Turn off the bypass button (Fig 2, Item 3) Service task
High or low medium pressure	First-stage regulator fault	Service task
Poor sounding whistle	Whistle dirty	Clean whistle flute and retest
Whistle not functioning correctly	Activation mechanism fault	Service task
Air leak from lung demand regulator	Ice particles on sealing elements	Press the front button (Fig 3, Item 2), allow a rush of air to pass through the regulator, then quickly press the reset button (Fig 3, Item 1) to switch off the positive pressure.
Air leak from quick connect cylinder coupling	Ice particles on sealing elements	Disconnect then reconnect the cylinder to the breathing apparatus (see the Quick Connect Cylinder Coupling Instructions for Use) and retest.

5 Maintenance

5.1 Maintenance table

Service and test the breathing apparatus, including out-of-use apparatus, in accordance with the maintenance table. Record all service details and testing. Refer also to the Instructions for Use for the lung demand regulator, face mask and other associated equipment.

Additional inspection and testing may be required in the country of use to ensure compliance with national regulations.

Component/System	Task	After use	Every month	Every year	Every 10 years
Complete apparatus	Clean and disinfect if necessary (see Section 5.2)	○			
	Visual inspection (see Section 3.5.1)	○	○		
	Functional testing (see Section 3.5.3)	○	○		
	Flow and static tests (see Note 1)			○	
Lung demand regulator	Clean and disinfect (see Note 2 and Section 5.2)	○			
First-stage regulator	Medium-pressure check (see Note 1)			○	
	Inspect the sintered filter (see Note 1 and Note 3)			○	
	Inspect the high-pressure connector O-ring (see Note 1 and Note 4)			○	
	Overhaul. Contact Dräger for the Repair Exchange (REX) service (see Note 5)				○
Cylinder	Charge cylinder to correct working pressure (see Section 5.3.1)	○			
	Check charged pressure (stored cylinders only)		○		
	Check test date of cylinder (carbon composite cylinders over 15 years old must be retired)		○		
	Recertification	According to national regulations in the country of use			
Cylinder valve	Overhaul	At the time of cylinder recertification			

Notes

○ Dräger recommendations.

- These maintenance tasks may only be carried out by Dräger or trained service personnel. Details of the tests are contained in the Technical Manual which is issued to service personnel that have attended a relevant Dräger maintenance course.
- Lightly lubricate the O-ring of the lung demand regulator as required (recommended lubricant is Dow Corning 111 Valve Lubricant and Sealant). Products other than the recommended lubricant are not tested and may damage the equipment.
- Replace the sintered filter if a drop in first-stage regulator performance is observed during a flow check or if it is visibly damaged.
- Replace the high-pressure connector O-ring if it is found to leak during functional testing or if the O-ring is visibly damaged.
- Where the breathing apparatus is subjected to a high level of use (in training establishments etc.), reduce the overhaul period for the first-stage regulator. In these circumstances, Dräger recommend that the overhaul frequency should be less than 5,000 applications of use. An application of use is defined as a single use of the fully assembled breathing apparatus, where the user breathes from the air cylinder. It does not include system pressurization for pre-operational checks.

5.2 Cleaning and disinfecting



CAUTION

Cleaning agents and disinfectants listed below are not manufactured by Dräger and have been reviewed only for compatibility when used to clean or disinfect the subject Dräger product(s). Read and comply with all instructions for use provided by the manufacturers of such agents and disinfectants. Dräger expressly disclaims all responsibility for any damage, personal injury or loss resulting from the use of such agents or disinfectants.

Do not exceed 86 °F (30 °C) for washing, disinfecting and rinsing solutions. Do not exceed 140 °F (60 °C) for drying, and remove components from the drying facility immediately when dry. Drying time in a heated dryer must not exceed 30 minutes.

Do not immerse pneumatic or electronic components in cleaning solutions or water.

If water is trapped and then freezes inside the pneumatic system of the breathing apparatus (such as the lung demand regulator), operation will be impaired. Prevent any liquid from entering, and thoroughly dry the breathing apparatus after cleaning to prevent this from occurring.

Refer also to the instructions for the lung demand regulator, face mask and other associated equipment.

5.2.1 Manual cleaning of the breathing apparatus (USA)

Cleaning and disinfecting materials:

- Cleaning agent – 1008 Green Liquid Hand Dish Wash
- Disinfecting agent – 800 Spur-Tex Disinfectant Cleaner-Deodorant (concentration: 1.6 % (2 fl oz per gallon))
- Use only clean lint-free cloths.

- Prepare cleaning solution as per manufacturer's instructions. Clean the breathing apparatus manually using a cloth moistened with cleaning solution to remove excess dirt.
- Prepare disinfecting solution as per manufacturer's instructions. Apply to all internal and external surfaces, ensuring that all surfaces remain visibly wet for 15 minutes.
- Rinse all components thoroughly with clean water to remove all cleaning and disinfecting agents.
- Dry all components using a dry cloth, in a heated dryer or in air.
- Contact service personnel or Dräger if disassembly of pneumatic or electronic components is required.

5.2.2 Manual cleaning of the breathing apparatus (Canada)

Cleaning and disinfecting materials:

- Cleaning agent – mild soap solution
- Disinfecting agent – Neutral Disinfectant Cleaner (concentration: 0.5 % (0.5 fl oz per gallon or 15 ml per 3.785 liters))
- Use only clean lint-free cloths.

- Prepare cleaning solution as per manufacturer's instructions. Clean the breathing apparatus manually using a cloth moistened with cleaning solution to remove excess dirt.
- Prepare disinfecting solution as per manufacturer's instructions. Apply to all internal and external surfaces, ensuring that all surfaces remain visibly wet for 10 minutes.
- Rinse all components thoroughly with clean water to remove all cleaning and disinfecting agents.
- Dry all components using a dry cloth, in a heated dryer or in air.
- Contact service personnel or Dräger if disassembly of pneumatic or electronic components is required.

5.3 Maintenance work

5.3.1 Air cylinder charging



WARNING

Air quality for compressed-air cylinders must conform to the minimum grade requirements for Type 1 gaseous air as defined in the CGA Commodity Specification for Air, G-7.1 (Grade D or higher quality).

Refer to the instructions supplied with the cylinder and the charging apparatus for recharging a compressed-air cylinder.

6 Storage

6.1 Storage preparation

- Extend the shoulder straps, waist belt and the head harness straps of the face mask.
- For storage, place the face mask in a protective bag (contact Dräger for supply of a suitable bag).
- Route rubber hoses in such a way that the bend radius is not too acute and the hose is not stretched, compressed or twisted.

6.2 Storage conditions

- Store the equipment between 5 °F and 77 °F (-15 °C and +25 °C). Ensure that the environment is dry, free from dust and dirt, and does not subject the equipment to wear or damage due to abrasion. Do not store the equipment in direct sunlight.
- Fix the breathing apparatus securely to any raised mounting point to prevent it from falling.

7 Disposal

Dispose of used batteries in accordance with national or local regulations. When required, dispose of other parts of the breathing apparatus, including electrical and electronic equipment, in line with any national or local environmental regulations.

8 Technical data

Compressed-air cylinders:

- 30 minutes to 60 minutes capacity
- 2216 psi or 4500 psi pressure
- Aluminum or composite materials.

Cylinder high-pressure connectors:

- 2216 psi connector to CGA 346
- 4500 psi connector to CGA 347.

Lung demand regulator to face mask connector:

- Dräger push-in connector.

Whistle warning (EOST) – Activation commencement range:

- 2216 psi cylinder: 600 psi to 510 psi
- 4500 psi cylinder: 1215 psi to 1035 psi.

9 Special instructions

9.1 Use of an independent air supply (supplied airline respirator (SAR) connection)



WARNING

Air quality must conform to the statutory requirements.

Use of an airline connection by a second person (buddy-breather) voids NIOSH approval.

The time required for the wearer to escape to a safe area must be within the remaining breathing time of the cylinder, taking into account the remaining air content in the cylinder and the breathing rate of the wearer.

Independent air supplies must meet the following standards:

- Type-1 gaseous air as defined in: CGA Commodity Specification for Air, G-71 (grade D or higher)
- Air supply pressure: 87 psi to 125 psi
- Airline hose length: 5 feet to 300 feet (maximum working hose length must not exceed 12 individual hose lengths)
- Airline flow rate: 550 liters/minute
- Approved for use at temperatures above -25 °F (-31.7 °C).

- Turn on the independent air supply.
- Connect the independent air supply coupling to the secondary supply hose (see the PSS Series Pneumatic Accessories Instructions for Use 3355853) and breathe normally.
- Close the cylinder valve (if the whistle sounds, silence it by taking several short deep breaths or momentarily operating the lung demand regulator bypass button (Fig 2, Item 3)).
- If any air supply problems are encountered, proceed as follows:
 - Open the cylinder valve to return to breathing from the attached cylinder.
 - Disconnect the independent air supply coupling.
 - Leave the hazardous area by the shortest and safest escape route, if necessary.

9.2 Cautions and limitations

- D – Air-line respirators can be used only when the respirators are supplied with respirable air meeting the requirements of CGA G – 7.1, Grade D or higher quality.
- E – Use only the pressure ranges and hose lengths specified in the User's Instructions.
- I – Contains electrical parts that may cause an ignition in flammable or explosive atmospheres.
- J – Failure to properly use and maintain this product could result in injury or death.
- M – All approved respirators shall be selected, fitted, used, and maintained in accordance with MSHA, OSHA, and other applicable regulations.
- N – Never substitute, modify, add, or omit parts. Use only exact replacement parts in the configuration as specified by the manufacturer.
- O – Refer to User's Instructions and/or maintenance manuals for information on use and maintenance of these respirators.
- S – Special or critical User's Instructions and/or specific use limitations apply. Refer to User's Instructions before donning.

S – Special or Critical Users Instructions

- Approved for use at temperatures above -25 °F (-31.7 °C).
- When used as a combination supplied-air respirator/self-contained breathing apparatus (SAR/SCBA), not more than 20 percent of the air supply can be used during entry.
- During supplied air use, the cylinder valve must remain closed. If the supplied air fails, open the cylinder valve and immediately proceed to fresh air.
- Supplied air source must meet the following criteria: pressure 87 psi to 125 psi, air flow rate at least 550 liters/minute.

Important Note: If it is decided to exit the working area with the airline disconnected or, in an emergency, if the air supply fails, breathe normally and immediately proceed as follows:

- Open the cylinder valve (counterclockwise) slowly, but fully, and breathe normally.
- Disconnect the hose of the independent air supply from the male coupling of the airline hose connection. Breathe normally and immediately leave the hazardous area by the shortest and safest route.

Safety Warning: The remaining duration begins from the time of opening the cylinder valve and disconnecting the independent air supply. The time required to allow the wearer to escape to a safe area must be within the remaining air capacity (volume) of the cylinder taking into account the breathing rate of the wearer.

10 Warranty information

Unless otherwise agreed between Dräger and the customer, the following shall apply in the event of defects of the product in material or workmanship: The customer shall contact the company where he bought the product ("Seller"). The warranty conditions agreed between the customer and the Seller shall apply. The product must be used in strict accordance with the Instructions for Use. Any use disregarding the Instructions for Use may void warranty.

11 Contact details

Any issues with the equipment, including damage, malfunction, or failure of the breathing apparatus that may present a hazard to the user should be reported to Dräger US Customer Service – Phone 1-800-858-1737

Contact with the certification organization may be reached at: NIOSH, NPPTL – Phone 1-412-386-4000