

DI GROOVED LIGHT-DUTY MECHANICAL TEE-THREADED OUTLET

Type: 3JS

Doc No: DS-400-3JS-01-E

1.0 PRODUCT OVERVIEW

This mechanical tee is one short style which works as a saddle-shaped joint for connecting one side of a pipe in the middle of a straight pipe, the branch pipe is a threaded connection.



Dimensions:

2 1/2"(DN65)– 8"(DN200)

Design Standard:

ISO6182, AWWA C606, GB 5135.11

Connection Standard:

ASME B36.10, ASTM A53-A53M, ISO 4200

Working Pressure:

175PSI-300PSI

Application:

The light-duty threaded outlet mechanical tee is suitable for medium and low pressure pipeline systems with nominal pressure 175-300 PSI, nominal size DN65-DN200, temperature range of - 20 °C-+180°C, which are widely applied in water supply and drainage, fire-fighting, air conditioning, etc.

Pipe Material:

Welded and seamless rolled steel pipes according to ASME B36.10, ASTM A53-A53M, ISO 4200, GB/T 21835

Surface Treatment:

- Electrophoretic painting
- Epoxy power painting
- Hot-dip galvanizing
- Black
- Others would be available upon clients' detailed request

2.0 APPROVALS



3.0 SPECIFICATIONS

Housing:

ASTM A536, Ductile iron 65-45-12

Gasket:

1、 EPDM Gasket, code E:

Temperature: $-34^{\circ}\text{C} \sim +110^{\circ}\text{C}$ ($-30 \sim +230^{\circ}\text{F}$) ;

Applicable media: water, gas, diluted acid (base), and other chemicals (excluding hydrocarbons)

Note: Strictly prohibit the use of oil and hydrocarbons.

2、 NBR, code D:

Temperature: $-29^{\circ}\text{C} \sim +82^{\circ}\text{C}$ ($-20 \sim +180^{\circ}\text{F}$) ;

Applicable media: Petroleum products, vegetable oils, mineral oils, etc.

Note: strictly prohibit use with high temperature substances.

3、 Silicone Rubber, code S:

Temperature: $-40^{\circ}\text{C} \sim +177^{\circ}\text{C}$ ($-40 \sim +350^{\circ}\text{F}$)

Applicable media: High temperature and dry air and some high temperature chemicals, drinking water and so on.

4、 Chloroprene Rubber, code LD:

Temperature: $-32^{\circ}\text{C} \sim +82^{\circ}\text{C}$ ($-26 \sim +180^{\circ}\text{F}$)

Applicable media: sea water

5、 Fluororubber, code F:

Temperature: $-20^{\circ}\text{C} \sim +180^{\circ}\text{C}$

Applicable media: Hot oil, some chemical products, good oxidation resistance.

Bolts/Nuts:

ANSI Heavy Hex Nut

1. Material: SAE J995 2.

2. Thread: ANSI B 1.1-1982, class 2B.

3. Surface Treatment: Zinc electroplated per ASTM B633 CLASS FE/ZN5 TYPE III , thickness $\geq 5\mu\text{m}$ per class SC1.

Metric Heavy Hex Nut

1. Material: ISO 898-2:1992 \ GB/T3098.2-2000 Class 8.

2. Thread: ISO 261, tolerance 6h for M10& M12, 7h for M16 and above.

3. Surface Treatment: Zinc Electroplated followed by a yellow chromate dip per ISO 2081 FE/ZN5, ISO4520 CLASS 1A.

ANSI Oval Neck Track Bolt

1. Material: SAE J429 5.

2. Thread: UNC thread per ANSI B 1.1 Class 2A.

3. Surface Treatment: Silver chromate electroplated per ASTM B633 CLASS FE/ZN5 TYPE III, thickness $\geq 5\mu\text{m}$ per class SC1.

Metric Oval Neck Track Bolt

1. Material: ISO 898-1: 1992 \ GB/T3098.1-2000 Class 8.8.
2. Thread: ISO metric thread per ISO 261, tolerance 6h.
3. Surface Treatment: Yellow chromate electroplated per ISO 2081 FE/ZN5 ISO4520 CLASS 1A.

4.0 DIMENSIONS AND PERFORMANCE

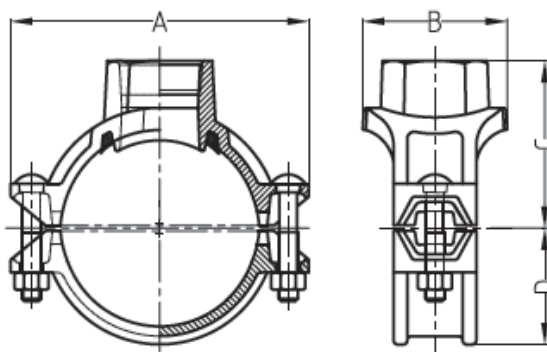

Nominal Size	Pipe O.D	Working Pressure	Hole Dia mm/in	Dimensions				Bolt Size
				A	B	C	D	
mm/in	mm/in	PSI/Mpa	+1.6,0/+0.063,0	mm/in	mm/in	mm/in	mm/in	mm/in
65×15 76.1×½	76.1×21.3 3.000×0.825	300 2.07	38 1.5	137 5.39	71 2.8	75 3.05	49.5 1.95	1/2×70 M12X70
65×20 76.1×¾	76.1×26.9 3.000×1.050	300 2.07	38 1.5	137 5.39	71 2.8	75 3.05	49.5 1.95	1/2×70 M12X70
65×25 76.1×1	76.1×33.7 3.000×1.315	300 2.07	38 1.5	137 5.39	71 2.8	75 3.05	49.5 1.95	1/2×70 M12X70
65×32 76.1×1¼	76.1×42.4 3.000×1.660	300 2.07	51 2	137 5.39	84.5 3.33	75 3.05	49.5 1.95	1/2×70 M12X70
65×40 76.1×1½	76.1×48.3 3.000×1.900	300 2.07	51 2	137 5.39	84.5 3.33	75 3.05	49.5 1.95	1/2×70 M12X70
80×15 3×½	88.9×21.3 3.500×0.825	300 2.07	38 1.5	150 5.91	71 2.8	68 2.68	55.5 2.19	1/2×75 M12X76
80×20 3×¾	88.9×26.9 3.500×1.050	300 2.07	38 1.5	150 5.91	71 2.8	68 2.68	55.5 2.19	1/2×75 M12X76
80×25 3×1	88.9×33.7 3.500×1.315	300 2.07	38 1.5	150 5.91	71 2.8	71 2.8	55.5 2.19	1/2×75 M12X76
80×32 3×1¼	88.9×42.4 3.500×1.660	300 2.07	51 2	150 5.91	84.5 3.33	74 2.91	55.5 2.19	1/2×75 M12X76
80×40 3×1½	88.9×48.3 3.500×1.900	300 2.07	51 2	150 5.91	84.5 3.33	74 2.91	55.5 2.19	1/2×75 M12X76
80×50	88.9×60.3	300	64	150	98	77	55.5	1/2×75

3×2	3.500×2.375	2.07	2.5	5.91	3.86	3.03	2.19	M12X76
100×15	108.1×21.3	300	38	172	77.5	85	64.5	1/2×75
108.0×½	4.250×0.825	2.07	1.5	6.77	3.05	3.35	2.54	M12X76
100×25	108.1×33.7	300	38	172	77.5	85	64.5	1/2×75
108.0×1	4.250×1.315	2.07	1.5	6.77	3.05	3.35	2.54	M12X76
100×32	108.1×42.4	300	51	172	88	85	64.5	1/2×75
108.0×¼	4.250×1.660	2.07	2	6.77	3.46	3.35	2.54	M12X76
100×40	108.0×48.3	300	51	172	88	85	64.5	1/2×75
108.0×½	4.250×1.900	2.07	2	6.77	3.46	3.35	2.54	M12X76
100×50	108.0×60.3	300	64	172	103.5	90.5	64.5	1/2×75
108.0×2	4.250×2.375	2.07	2.5	6.77	4.19	3.56	2.54	M12X76
100×65	108.0×76.1	300	70	172	103.5	97.5	64.5	1/2×75
108.0×76.1	4.250×3.000	2.07	2.75	6.77	4.07	3.84	2.54	M12X76
Nominal Size	Pipe O.D	Working Pressure	Hole Dia mm/in	Dimensions				Bolt Size
				A	B	C	D	
mm/in	mm/in	PSI/Mpa	+1.6,0/+0.063,0	mm/in	mm/in	mm/in	mm/in	mm/in
100×15	114.3×21.3	300	38	178	77.5	82	67.5	1/2×75
4×½	4.500×0.825	2.07	1.5	7.01	3.05	3.23	2.66	M12X76
100×20	114.3×26.9	300	38	178	77.5	82	67.5	1/2×75
4×¾	4.500×1.050	2.07	1.5	7.01	3.05	3.23	2.66	M12X76
100×25	114.3×33.7	300	38	178	77.5	89.5	67.5	1/2×75
4×1	4.500×1.315	2.07	1.5	7.01	3.05	3.52	2.66	M12X76
100×32	114.3×42.4	300	51	178	88	89.5	67.5	1/2×75
4×¼	4.500×1.660	2.07	2	7.01	3.46	3.53	2.66	M12X76
100×40	114.3×48.3	300	51	178	88	89.5	67.5	1/2×75
4×½	4.500×1.900	2.07	2	7.01	3.46	3.53	2.66	M12X76
100×50	114.3×60.3	300	64	178	103.5	92	67.5	1/2×75
4×2	4.500×2.375	2.07	2.5	7.01	4.07	3.62	2.66	M12X76
100×65	114.3×73.0	300	70	178	103.5	98	67.5	1/2×75
4×2½	4.500×2.875	2.07	2.75	7.01	4.07	3.86	2.66	M12X76
100×65	114.3×76.1	300	70	178	103.5	98	67.5	1/2×75
4×76.1	4.500×3.000	2.07	2.75	7.01	4.07	3.86	2.66	M12X76
100×80	114.3×88.9	300	89	178	124	98	67.5	1/2×75
4×3	4.500×3.500	2.07	3.5	7.01	4.88	3.86	2.66	M12X76
125×25	133.0×33.7	300	38	203	77	98	77.5	5/8×85
133.0×1	5.250×1.315	2.07	1.5	7.99	3.03	3.86	3.05	
125×32	133.0×42.4	300	51	203	91	102	77.5	5/8×85
133.0×1.25	5.250×1.660	2.07	2	7.99	3.58	4.01	3.05	
125×40	133.0×48.3	300	51	203	91	102	77.5	5/8×85
133.0×½	5.250×1.900	2.07	2	7.99	3.58	4.01	3.05	
125×50	133.0×60.3	300	64	203	110	105	77.5	5/8×85
133.0×2	5.250×2.375	2.07	2.5	7.99	4.33	4.13	3.05	
125×65	133.0×76.1	300	70	203	110	113	77.5	5/8×85
133.0×76.1	5.250×3.000	2.07	2.75	7.99	4.33	4.45	3.05	
125×80	133.0×88.9	300	89	203	132	110	77.5	5/8×85

133.0×3	5.250×3.500	2.07	3.5	7.99	5.12	4.33	3.05	
125×25	139.7×33.7	300	38	210	77	100	82	5/8×85
139.7×1	5.500×1.315	2.07	1.5	8.27	3.03	3.94	3.23	M16X85
125×32	139.7×42.4	300	51	210	91	105	82	5/8×85
139.7×1¼	5.500×1.660	2.07	2	8.27	3.58	4.13	3.23	M16X85
125×40	139.7×48.3	300	51	210	91	105	82	5/8×85
139.7×1½	5.500×1.900	2.07	2	8.27	3.58	4.13	3.23	M16X85
Nominal Size	Pipe O.D	Working Pressure	Hole Dia mm/in	Dimensions				Bolt Size
				A	B	C	D	
mm/in	mm/in	PSI/Mpa	+1.6,0/+0.063,0	mm/in	mm/in	mm/in	mm/in	mm/in
125×50	139.7×60.3	300	64	210	110	108	82	5/8×85
139.7×2	5.500×2.375	2.07	2.5	8.27	4.33	4.25	3.23	M16X85
125×65	139.7×76.1	300	70	210	110	115	82	5/8×85
139.7×76.1	5.500×3.000	2.07	2.75	8.27	4.33	4.53	3.23	M16X85
125×80	139.7×88.9	300	89	210	130	115	82	5/8×85
139.7×3	5.500×3.500	2.07	3.5	8.27	5.12	4.53	3.23	M16X85
125×100	139.7×114.3	300	114	210	153	118	82	5/8×85
139.7×4	5.500×4.500	2.07	4.5	8.27	6.02	4.65	3.23	M16X85
150×25	159.0×33.7	300	38	227	77	110	91	5/8×85
159.0×1	6.250×1.315	2.07	1.5	8.94	3.03	4.33	3.58	M16X85
150×32	159.0×42.4	300	51	227	92.5	112	91	5/8×105
159.0×1¼	6.250×1.660	2.07	2	8.94	3.64	4.41	3.58	M16X108
150×40	159.0×48.3	300	51	227	92.5	112	91	5/8×105
159.0×1½	6.250×1.900	2.07	2	8.94	3.64	4.41	3.58	M16X108
150×50	159.0×60.3	300	64	227	110	116.5	91	5/8×105
159.0×2	6.250×2.375	2.07	2.5	8.94	4.33	4.59	3.58	M16X108
150×65	159.0×76.1	300	70	227	110	121.5	91	5/8×105
159.0×76.1	6.250×3.000	2.07	2.75	8.94	4.33	4.78	3.58	M16X108
150×80	159.0×88.9	300	89	227	130	123.5	91	5/8×105
159.0×3	6.250×3.500	2.07	3.5	8.94	5.12	4.86	3.58	M16X108
150×100	159.1×114.3	300	114	227	155	127	91	5/8×105
159.0×4	6.250×4.500	2.07	4.5	8.94	6.1	5	3.58	M16X108
150×15	165.1×21.3	300	38	235	77	115	94.5	5/8×105
165.1×½	6.500×0.825	2.07	1.5	9.25	3.03	4.53	3.72	M16X108
125×20	165.1×26.9	300	38	235	77	115	94.5	5/8×105
165.1×¾	6.500×1.050	2.07	1.5	9.25	3.03	4.53	3.72	M16X108
150×25	165.1×33.7	300	38	235	77	115	94.5	5/8×105
165.1×1	6.500×1.315	2.07	1.5	9.25	3.03	4.53	3.72	M16X108
150×32	165.1×42.4	300	51	235	92.5	115	94.5	5/8×105
165.1×1¼	6.500×1.660	2.07	2	9.25	3.64	4.53	3.72	M16X108
150×40	165.1×48.3	300	51	235	92.5	115	94.5	5/8×105
165.1×1½	6.500×1.900	2.07	2	9.25	3.64	4.53	3.72	M16X108
150×50	165.1×60.3	300	64	235	110	120	94.5	5/8×105
165.1×2	6.500×2.375	2.07	2.5	9.25	4.33	4.72	3.72	M16X108
150×65	165.1×76.1	300	70	235	110	125	94.5	5/8×105
165.1×76.1	6.500×3.000	2.07	2.75	9.25	4.33	4.92	3.72	M16X108

Nominal Size	Pipe O.D	Working Pressure	Hole Dia mm/in	Dimensions				Bolt Size
				A	B	C	D	
mm/in	mm/in	PSI/Mpa	+1.6,0/+0.063,0	mm/in	mm/in	mm/in	mm/in	mm/in
150×80 165.1×3	165.1×88.9 6.500×3.500	300 2.07	89 3.5	235 9.25	130 5.12	125 4.92	94.5 3.72	5/8×105 M16X108
150×100 165.1×4	165.1×114.3 6.500×4.500	300 2.07	114 4.5	240 9.45	155 6.1	130 5.12	94.5 3.72	5/8×105 M16X108
150×25 6×1	168.3×33.7 6.500×1.315	300 2.07	38 1.5	240 9.45	77 3.03	115 4.53	96.5 3.8	5/8×105 M16X108
150×32 6×1¼	168.3×42.4 6.500×1.660	300 2.07	51 2	240 9.45	92.5 3.64	115 4.53	96.5 3.8	5/8×105 M16X108
150×40 6×1½	168.3×48.3 6.500×1.900	300 2.07	51 2	240 9.45	92.5 3.64	115 4.53	96.5 3.8	5/8×105 M16X108
150×50 6×2	168.3×60.3 6.625×2.375	300 2.07	64 2.5	240 9.45	110 4.33	121 4.76	96.5 3.8	5/8×105 M16X108
150×65 6×2½	168.3×73.0 6.625×2.875	300 2.07	70 2.75	240 9.45	110 4.33	127 5	96.5 3.8	5/8×105 M16X108
150×65 6×2½	168.3×76.0 6.625×3.000	300 2.07	70 2.75	240 9.45	110 4.33	127 5	96.5 3.8	5/8×105 M16X108
150×80 6×3	168.3×88.9 6.625×3.500	300 2.07	89 3.5	240 9.45	130 5.12	127 5	96.5 3.8	5/8×105 M16X108
150×100 6×4	168.3×114.3 6.625×4.500	300 2.07	114 4.5	240 9.45	155 6.1	130 5.12	96.5 3.8	5/8×105 M16X108
200×25 8×1	219.0×33.7 8.625×1.315	300 2.07	38 1.5	300 11.81	78 3.07	140 5.51	123 4.84	5/8×105 M16X108
200×32 8×1¼	219.1×42.4 8.625×1.660	300 2.07	51 2	300 11.81	96.5 3.8	140 5.51	123 4.84	5/8×105 M16X108
200×40 8×1½	219.1×48.3 8.625×1.900	300 2.07	51 2	300 11.81	96.5 3.8	143 5.63	123 4.84	5/8×105 M16X108
200×50 8×2	219.1×60.3 8.625×2.375	300 2.07	64 2.5	300 11.81	117 4.61	149 5.87	123 4.84	5/8×105 M16X108
200×65 8×2½	219.1×73.0 8.625×2.875	300 2.07	70 2.75	300 11.81	117 4.61	155 6.1	123 4.84	5/8×105 M16X108
200×65 8×76.1	219.1×76.1 8.625×3.000	300 2.07	70 2.75	300 11.81	117 4.61	155 6.1	123 4.84	5/8×105 M16X108
200×80 8×3	219.1×88.9 8.625×3.500	300 2.07	89 3.5	300 11.81	133.5 5.25	155 6.1	123 4.84	5/8×105 M16X108
200×100 8×4	219.1×114.3 8.625×4.500	300 2.07	114 4.5	300 11.81	164 6.45	160 6.3	123 4.84	5/8×105 M16X108

5.0 REFERENCE MATERIALS

Approved certification for Grooved Fittings and Couplings

I-JM-Grooved fitting: Installation Instructions for grooved fittings and

couplings