



Model REL-BL Full Port Ball Valves

Product Description

Reliable Model REL-BL full port ball valves are cULus Listed and FM Approved as trim and drain valves for fire protection systems. Table A indicates the rated working pressures. The valves feature a forged brass valve body with FNPT end connections.

Installation

The Reliable Full Port Ball Valve shall be installed in accordance with NFPA 13, "Standard for the Installation of Sprinkler Systems," as well as the requirements of any authorities having jurisdiction. Verify compatibility of the Full Port Ball Valve materials with the water supply and the environment where the valve will be installed prior to installation.

WARNING: Model REL-BL ball valves contain lead and are not for use in systems carrying water intended for human consumption.

Maintenance

The owner is responsible for maintaining the fire protection system in proper operating condition. Any system maintenance or testing that involves placing a control valve out of service will eliminate the fire protection that is provided by the fire protection system.

The Reliable Full Port Ball Valve shall periodically be given a thorough inspection and test. NFPA 25, "Inspection, Testing and Maintenance of Water Based Fire Protection Systems," provides minimum maintenance requirements. Inspect the valve for corrosion, damage, and wear as required and replace as necessary. Increase the frequency of inspections when the valve is exposed to corrosive conditions or chemicals that could impact the valve materials.

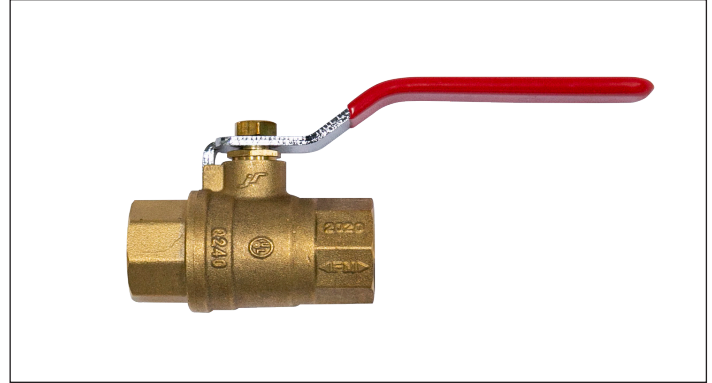

Model REL-BL Full Port Ball

Ordering Information

Specify the following when ordering:

Valve Size

- 1/4" (8 mm)
- 1/2" (15 mm)
- 3/4" (20 mm)
- 1" (25 mm)
- 1-1/4" (32 mm)
- 1-1/2" (40 mm)
- 2" (50 mm)

Table A

Valve Size	Pressure Rating	Approvals
1/4" (8 mm)	600 psi (41.4 bar)	cULus Listed
1/2" (15 mm)	600 psi (41.4 bar)	cULus Listed
	300 psi (20.7 bar)	FM Approved
3/4" (20 mm)	600 psi (41.4 bar)	cULus Listed
	300 psi (20.7 bar)	FM Approved
1" (25 mm)	600 psi (41.4 bar)	cULus Listed
	300 psi (20.7 bar)	FM Approved
1-1/4" (32 mm)	600 psi (41.4 bar)	cULus Listed
	300 psi (20.7 bar)	FM Approved
1-1/2" (40 mm)	600 psi (41.4 bar)	cULus Listed
	300 psi (20.7 bar)	FM Approved
2" (50 mm)	300 psi (20.7 bar)	cULus Listed, FM Approved

Model REL-BL Full Port Ball Valves

Technical Specifications

Pressure Rating:

See Table A

Material Specifications

Body: C37700 Brass Alloy
Bonnet: C37700 Brass Alloy
Seat: PTFE
Ball: C37700 Brass Alloy
Stem: HPb59-1 Brass Alloy
Packing: PTFE
Gland: C37700 Brass Alloy
Handle: Q235A Steel Alloy
Nut: Q235A Steel Alloy

End Connections

Female NPT

Listings and Approvals

cULus Listed (1/4" - 2")
 FM Approved (1/2" - 2")

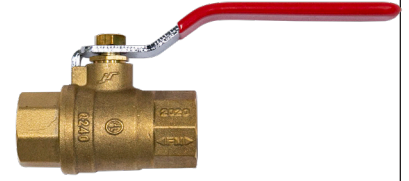

Model REL-BL Full Port Ball Valve Dimensions

Figure 1

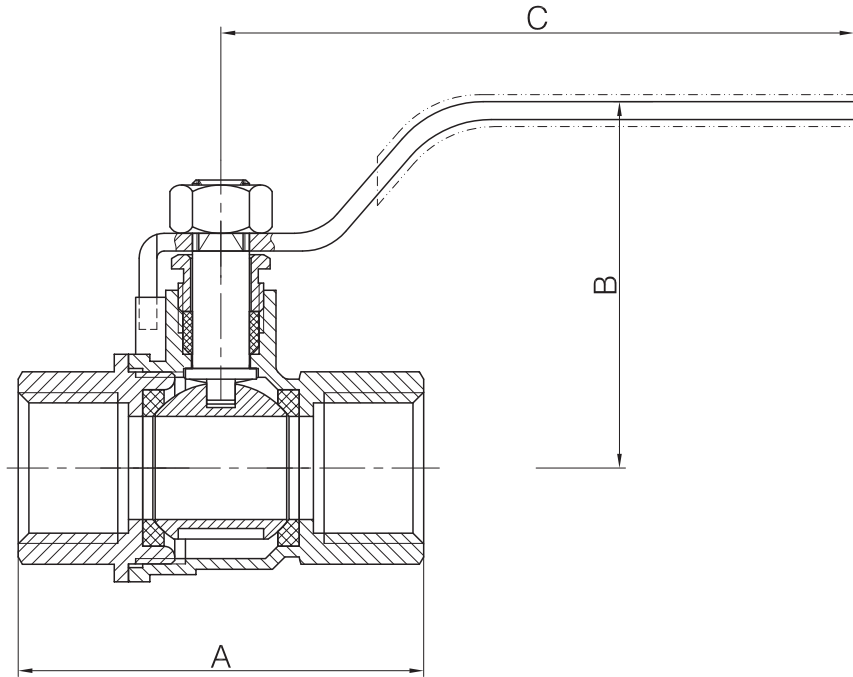

Dimensions in. (mm)

Table B

Valve Size	A	B	C
1/4" (8 mm)	1-3/4" (44)	1-13/16" (46)	3-1/2" (89)
1/2" (15 mm)	2-1/4" (57)	2" (51.5)	3-1/2" (89)
3/4" (20 mm)	2-1/2" (63)	2-3/8" (61)	4-1/8" (104)
1" (25 mm)	3" (75.5)	2-1/2" (63.5)	4-5/8" (117.5)
1-1/4" (32 mm)	3-7/16" (86.5)	2-13/16" (71)	4-5/8" (117.5)
1-1/2" (40 mm)	3-11/16" (94.2)	3-3/4" (94.5)	5-11/16" (145)
2" (50 mm)	4-1/4" (108)	4" (102)	5-11/16" (145)