

### Alarm Check Valve

**MODEL: NX009**



**175 psi (12 bar), 4" & 6" (DN100 & DN150), VERTICAL INSTALLATION**

#### GENERAL DESCRIPTION

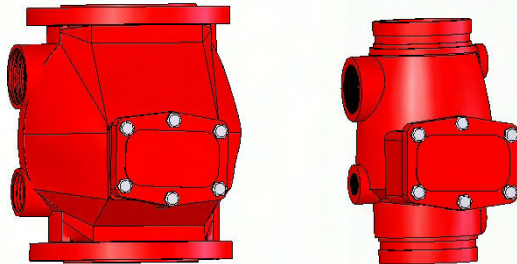

**M**odel NX009 Alarm Check Valve is a wet pipe sprinkler system water supply check valve that makes possible the installation of sprinkler systems in buildings not subject to freezing temperatures. It is designed so that water pressure in the piping system will hold back water pressure at the valve until a significant flow of water occurs.

**T**he Alarm Check Valve serves as a check valve by trapping pressurized water above the clapper and preventing reverse flow from sprinkler piping.

**T**he valve is trimmed with a water bypass line. The bypass line allows pressure surges to enter

the system and to be trapped above the alarm check valve's clapper without the clapper lifting and causing false alarms.

**W**hen a significant sustained flow of water occurs, such as from an open sprinkler, the alarm valve's clapper lifts and allows water to enter the system. Simultaneously, water enters an intermediate chamber, which allows the water to activate an alarm either through an optional water motor alarm and/or through a water pressure alarm. These alarms continue to sound until the flow of water is stopped.

**T**he NX009 Alarm Check Valve should be installed vertically on wet-pipe sprinkler systems with constant pressure or variable pressure water supplies. The valve is made suitable for use on variable pressure water supplies by adding the optional retard chamber to the standard trim.

**T**he valve is available with a flanged inlet and flanged outlet or with a grooved inlet and grooved outlet.

#### TECHNICAL SPECIFICATIONS

Size	4" (DN100)		6" (DN150)	
Inlet Connection Style	Flange	Groove	Flange	Groove
Outlet Connection Style	Flange	Groove	Flange	Groove
Shipping Weight	55 lbs / 25 kg	51 lbs / 23 kg	75 lbs / 34 kg	66 lbs / 30 kg
Max. Working Pressure	175 psig / 1.2 MPa (12 bar)			
Factory Hydro Test	100% @ 350 psig / 2.4 MPa (24 bar)			
Standard Finish	Red Painted			
Flange & Groove Specification	Flange: Class 150 ANSI B16.1 & Groove: C606 ANSI / AWWA			
Required Accessories	Standard Trim			
Optional Accessories	Retard Chamber, Water Motor Alarm, Alarm Pressure Switch			
Installation Manner	Vertically			
Listings and Approvals	UL (United States)			

#### FRICION LOSS

**F**or use in hydraulic calculations, the pressure loss through the Alarm Check Valves may be expressed in equivalent length of pipe, based

on Hazen & Williams formula with C=120 based on ANSI standard wall straight pipe.

**4" Valve = 28 feet (8.5 m)**

**6" Valve = 32 feet (9.8 m)**

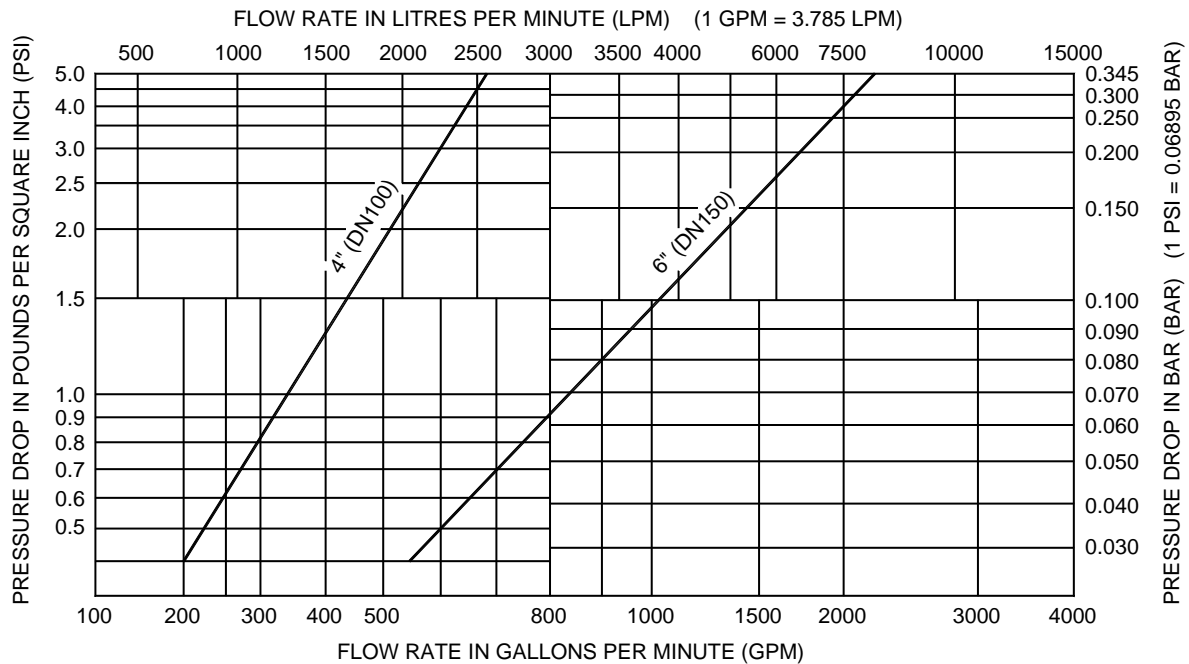

**Figure 1: Nominal Hydraulic Friction Loss of Model NX009 Alarm Check Valve**

### TRIM PACKAGES

**M**odel NX009 Alarm Check Valve is listed and/or approved with specific trim for use up to 175 psig / 1.2 MPa (12 bar). No substitutions or omissions, in part or in full, are allowed. Additional accessories to the standard trim packages are required for a complete system meeting the requirements of the applicable rules and codes. See appropriate technical data for additional information.

#### **STANDARD TRIM PACKAGES include:**

1. All necessary nipples and fittings
2. All standard trim accessories
3. All necessary gauges

#### **OPTIONAL ACCESSORIES**

ORDER SEPARATELY

- Retard Chamber

The Retard Chamber is required when the NX009 Alarm Check Valve is installed on systems with a variable pressure water supply in order to reduce the possibility of false alarms. Refer to the NX015 Retard Chamber technical data TD01911.

#### **Water Motor Alarm**

The NX009 Alarm Check Valve is designed to activate a mechanical alarm during a sustained flow of water (such as the flow required by an open sprinkler) causes the alarm check valve's clapper to lift from its seat. Refer to the NX010 Water Motor Alarm technical data TD01211.

#### **Alarm Pressure Switch**

The NX009 Alarm Check Valve trim allows installation of pressure switches to operate local electric alarms and/or remote electric alarms during a sustained flow of water (such as the flow requires by an open sprinkler). Refer to Alarm Pressure Switch technical data.

### VALVE DESCRIPTION

#### **DIMENSIONS**

inch (mm)

Valve Size	H	H <sub>1</sub>	H <sub>2</sub>	H <sub>3</sub>	H <sub>4</sub>	H <sub>5</sub>	H <sub>6</sub>
4" Flange	10.625 (270)	0.080 (2.0)	0.938 (23.9)	1.563 (40)	3.281 (83)	7.594 (193)	9.063 (230)
4" Groove	11.0 (280)	0.625 (15.9)	0.375 (9.5)	2.0 (50)	3.656 (93)	8.0 (203)	9.063 (230)
6" Flange	13.625 (346)	0.080 (2.0)	0.938 (23.9)	2.087 (53)	4.375 (111)	10.625 (270)	9.625 (244)
6" Groove	13.625 (346)	0.625 (15.9)	0.375 (9.5)	2.087 (53)	4.375 (111)	10.625 (270)	9.625 (244)

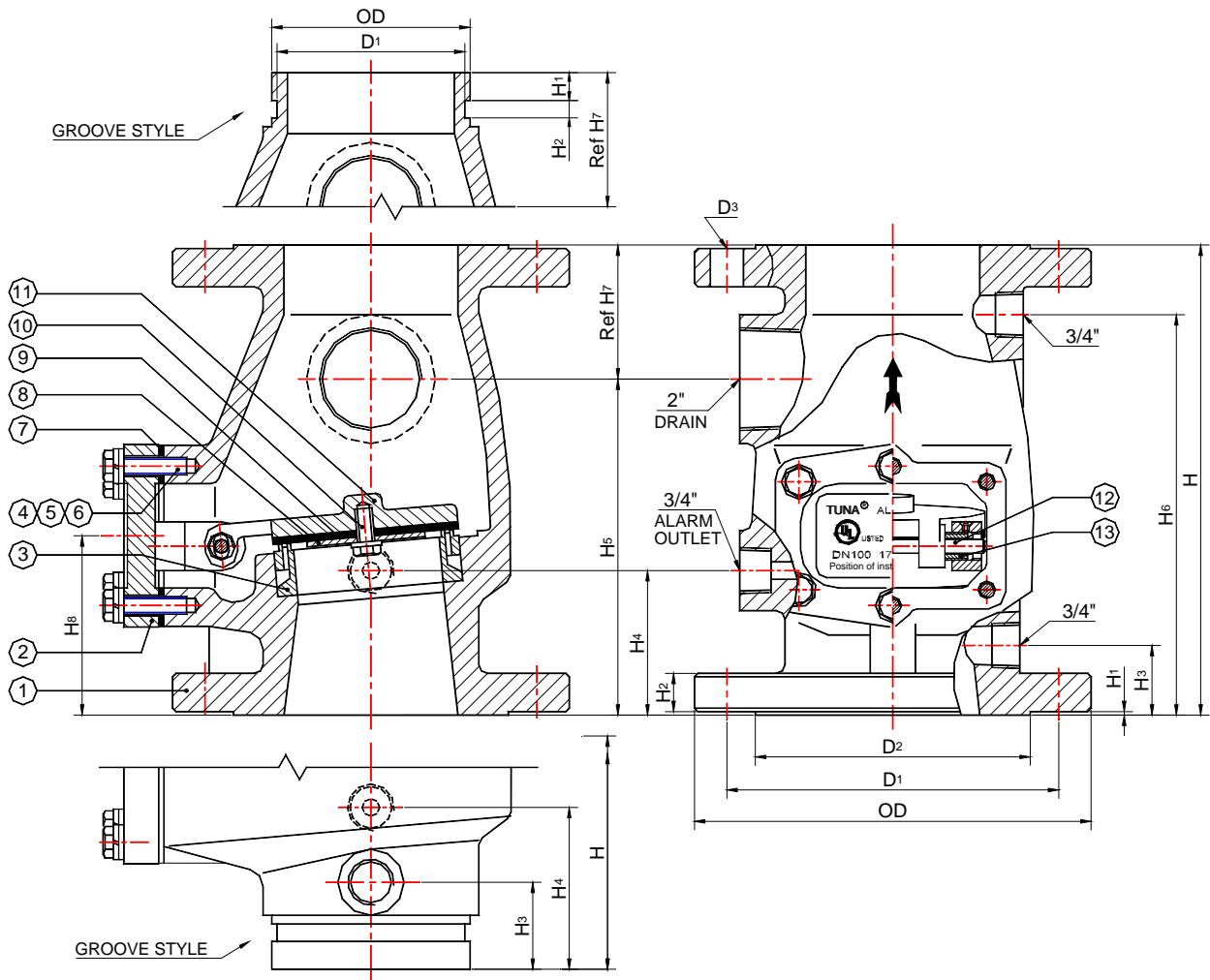

Figure 2: Model NX009 Alarm Check Valve, Partial Sections

### DIMENSIONS

inch (mm)

Valve Size	RefH <sub>7</sub>	H <sub>8</sub>	OD	D <sub>1</sub>	D <sub>2</sub>	D <sub>3</sub>
4" Flange	3.031 (77)	4.063 (103)	Ø9.0 (228.6)	Ø7.5 (190.5)	Ø6.188 (157.2)	8XØ0.750 (19)
4" Groove	3.031 (77)	4.063 (113)	Ø4.5 (114.3)	Ø4.334 (110.1)	—	—
6" Flange	3.0 (76)	5.219 (132)	Ø11.0 (279.4)	Ø9.5 (241.3)	Ø8.5 (215.9)	8XØ0.875 (23)
6" Groove	3.0 (76)	5.219 (132)	Ø6.625 (168.3)	Ø6.455 (164.0)	—	—

### PARTS

No.	Part Name	Qty.	Part No.		Material	Remarks
			4" (DN100)	6" (DN150)		
1	Valve Body (Flange Style)	1	0111 1430 0001	0111 1630 0001	Ductile Iron: 65-45-12	
1	Valve Body (Groove Style)	1	0111 1470 0001	0111 1670 0001	Ductile Iron: 65-45-12	
2	Cover Plate	1	0111 1430 0002	0111 1630 0002	Ductile Iron: 65-45-12	
3	Seat Ring	1	0111 1430 0003	0111 1630 0003	Brass: C87400	
4	Cover Plate Bolt	6	M10X35	M12X40	Steel, Zinc Plated	
5	Spring Washer	6	10	12	Steel, Zinc Plated	

No.	Part Name	Qty.	Part No.		Material	Remarks
			4" (DN100)	6" (DN150)		
6	Flat Washer	6	10	12	Steel, Zinc Plated	
7	Cover Plate Gasket	1	0111 1430 0004	0111 1630 0004	Rubber SBR	
8	Clapper Seal Retainer	1	0111 1430 0005	0111 1630 0005	Stainless Steel: 304H	
9	Clapper Seal	1	0111 1430 0006	0111 1630 0006	EPDM	
10	Clapper Screw	1	M12X15	M12X15	Stainless Steel: 304H	
11	Clapper	1	0111 1430 0007	0111 1630 0007	Brass: C87400	
12	Clapper Shaft	1	0111 1430 0008	0111 1630 0008	Stainless Steel: 304	
13	Clapper Busing	2	0111 1430 0009	0111 1630 0009	Brass: C37710	

### TRIM DESCRIPTION

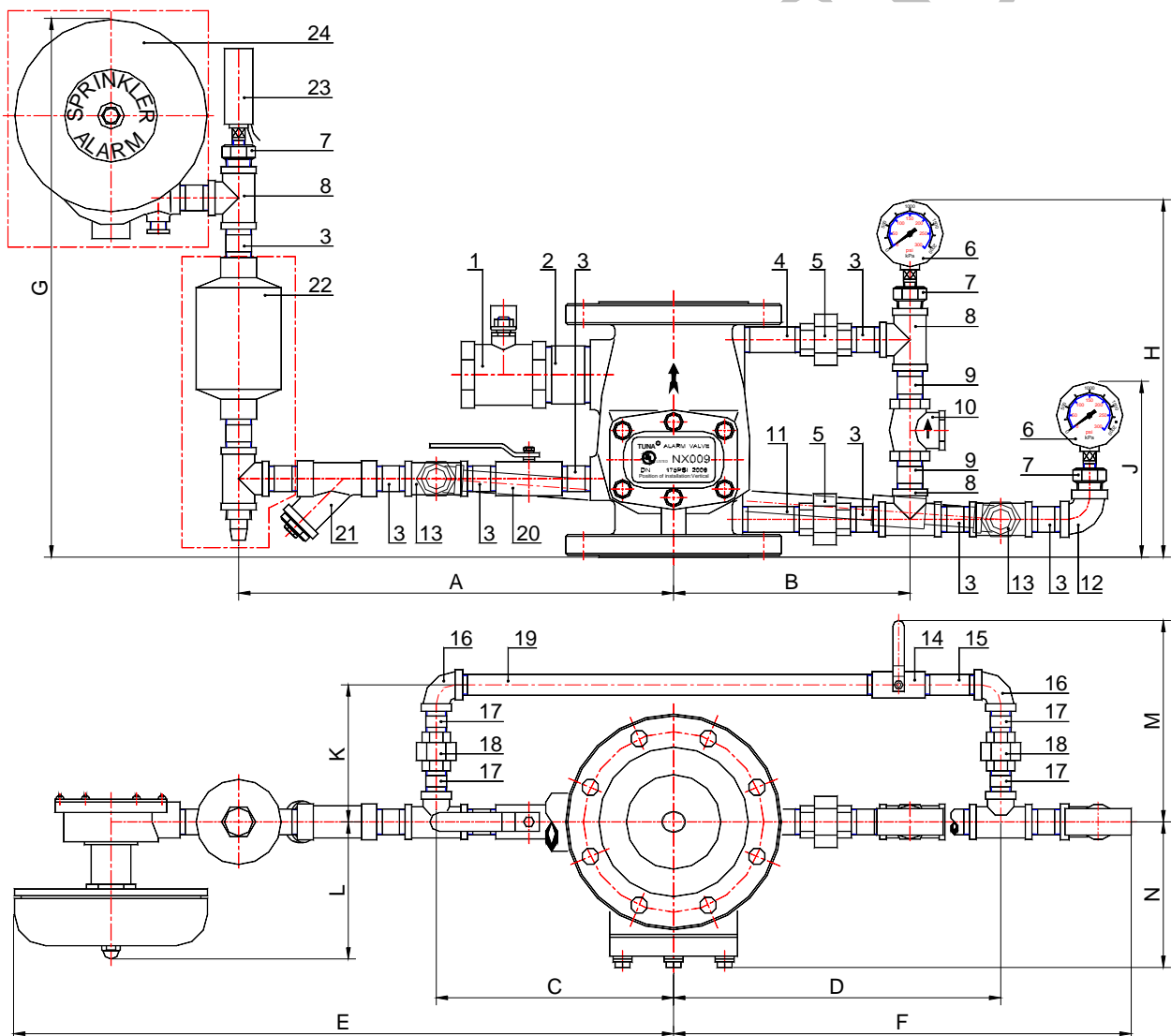

Figure 3: Model NX009 Alarm Check Valve, Vertical Trim

### DIMENSIONS

inch (mm)

Valve Size	A	B	C	D	E	F	G
4" Flange	18.2 (460)	9.8 (250)	9.8 (250)	13.6 (346)	27.6 (700)	19.0 (484)	22.4 (570)
4" Groove	18.2 (460)	9.8 (248)	9.8 (250)	13.6 (344)	27.6 (700)	19.0 (482)	22.8 (580)
6" Flange	19.4 (494)	11.2 (283)	11.2 (284)	15.0 (379)	28.9 (734)	20.4 (517)	23.5 (598)
6" Groove	19.4 (494)	11.2 (285)	11.2 (284)	15.0 (381)	28.9 (734)	20.4 (519)	23.5 (598)

Valve Size	H	J	K	L	M	N
4" Flange	15.3 (388)	7.4 (188)	5.7 (145)	5.7 (145)	8.4 (213)	6.1 (154)
4" Groove	15.3 (388)	7.8 (198)	5.7 (145)	5.7 (145)	8.4 (213)	6.1 (154)
6" Flange	15.8 (402)	7.9 (200)	5.7 (145)	5.7 (145)	8.4 (213)	7.5 (191)
6" Groove	15.8 (402)	7.9 (200)	5.7 (145)	5.7 (145)	8.4 (213)	7.5 (191)

### BILL OF MATERIALS

No.	Description	Qty.	Remarks
1	Ball Valve 2"	1	Main Drain Valve (Normally Closed), Type F1361FP
2	Nipple 2"X3¼" (80)	1	
3	Nipple ¾"X2" (50)	8	
4	Nipple ¾"X3¼" (80)	1	
5	Union ¾"	2	
6	Pressure Gauge 0~300psi / 2MPa	2	Supply Pressure and System Pressure, Type Y70B
7	Bushing ¾"X¼"	3	
8	Galvanized Steel: G10080	3	
9	Nipple ¾" X2" (50)	2	4" Groove Style
	Nipple ¾" X1¼" (45)	2	
10	Check Valve ¾"	1	06404, PN16, Bypass line
11	Nipple ¾" X3¼" (80)	1	4" Groove Style
	Nipple ¾" X3¾" (85)	1	
	Nipple ¾" X4" (100)	1	
12	90° Elbow ¾"	1	
13	Tee ¾"X½"X¾"	2	
14	Ball Valve ½"	1	Alarm Test Valve (Normally Closed), Type F1361FP
15	Nipple ½"X2¾" (70)	1	
16	90° Elbow ½"	2	
17	Nipple ½"X1⅝" (40)	4	
18	Union ½"	2	
19	Nipple ½"X17⅝" (453)	1	4" Flange Style
	Nipple ½"X17¾" (451)	1	4" Groove Style
	Nipple ½"X20½" (521)	1	6" Flange Style
	Nipple ½"X20½" (523)	1	6" Groove Style
20	Ball Valve ¾"	1	Alarm Shut-off Valve (Open Normally)
21	Strainer ¾"	1	Type F1191Y
22	Retard Chamber Assembly	1	Optional, Ordered For Variable Pressure Systems, NX015
23	Alarm Pressure Switch	1	Optional, Type PS75
24	Water Motor Alarm	1	Optional, Model NX010

### INTRODUCTION

The trim sets for the Model NX009 Alarm Valve are arranged for rapid, easy and compact attachment, and serves as connection points to Alarm and other devices. The Trim also serves as means for testing the operation of the alarm devices without causing the system to operate.

#### Constant Pressure Closed Drain

This trim set is used where water supply pressure does not vary, such as tank supplies. An automatic draining is provided to drain the mechanical sprinkler alarm line. This drain connection should be piped separately from the 2" (50mm) main drain.

#### Variable Pressure With Open Retard Chamber Drain

Retard Chamber is required. This trim set is used where water supply pressures vary, such as encountered with city water supplies. An open drip cup should be provided to drain the retard chamber and the mechanical sprinkler alarm line. This drain connection should be piped separately from the 2" main drain.

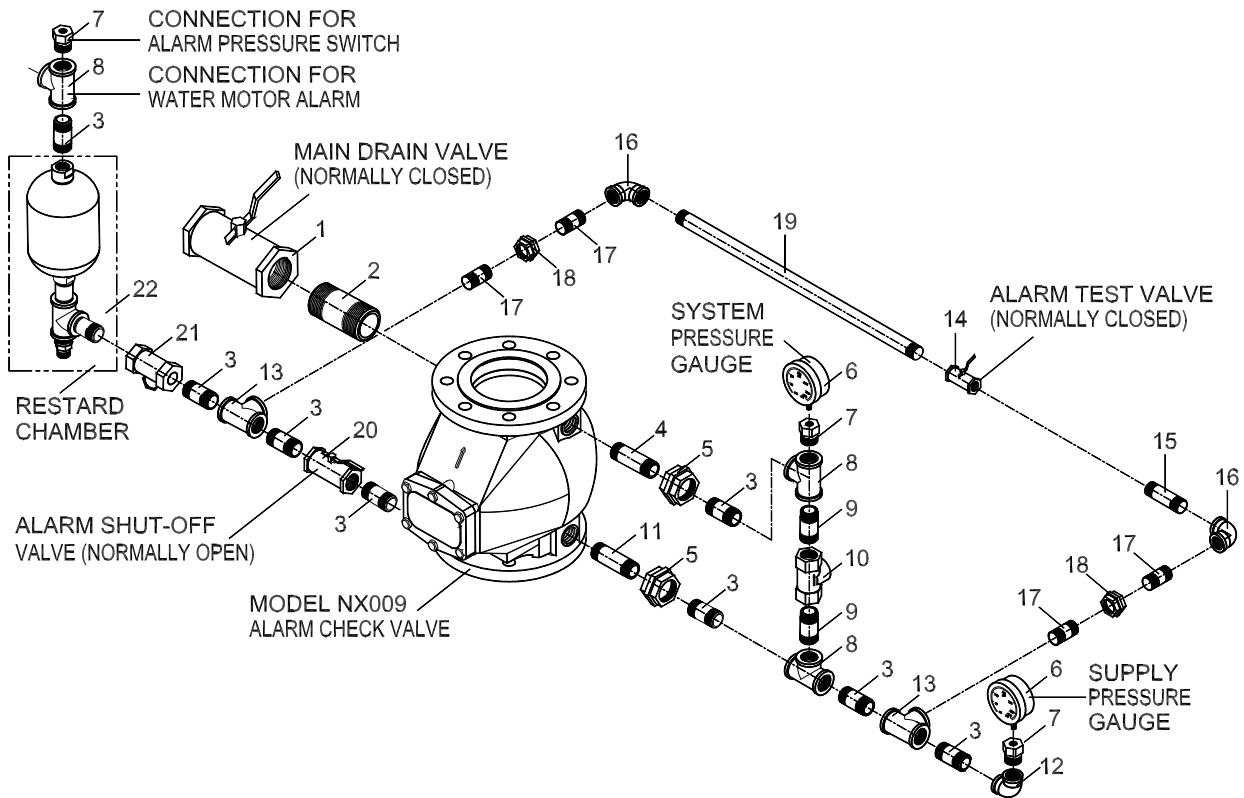

**Figure 4: Model NX009 Alarm Check Valve, Variable Pressure Open Drain Trim**

### OPERATION

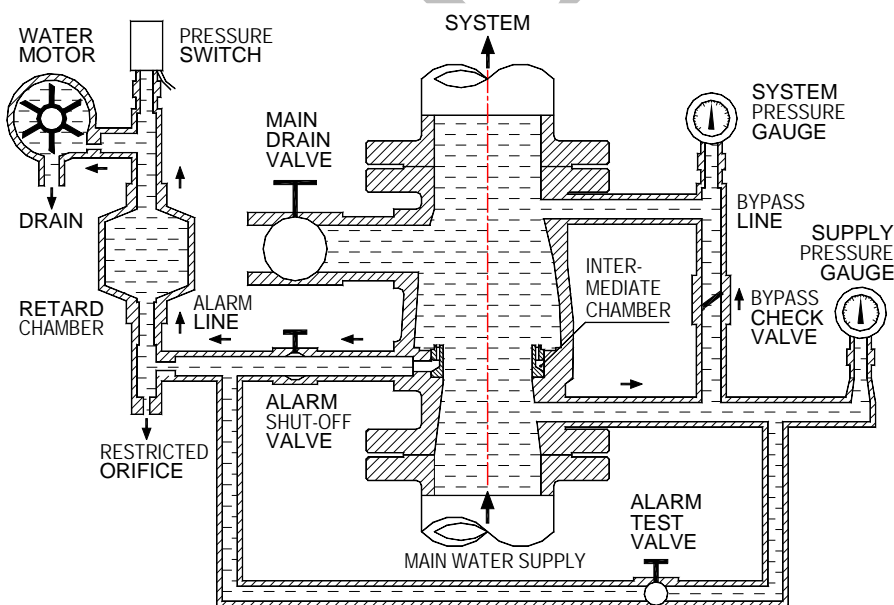

**Figure 5: Model NX009 Alarm Check Valve Operation**

**W**hen the fire protection system is initially being pressurized, water will flow into the system until the water supply and system pressure become equalized. The Alarm Check Valve traps pressure above the

Clapper and prevents the reverse flow of water. Once the pressures have stabilized, the Alarm Check Valve is in service and the intermediate chamber in the Seat Ring is sealed. Thus, with the Alarm Check Valve set for service, there is no flow through the alarm port to the alarm devices (i.e., Water Motor Alarm and/or Alarm Pressure Switch).

**W**hen a sustained flow of water occurs, such as an operated sprinkler head or an open inspector's test connection, the Clapper lifts from its closed position. Water is then permitted to flow into the intermediate chamber in the Seat Ring. Then water

flows from the intermediate chamber to the alarm line and activates the system's alarms. These alarms continue to sound until the flow of water stop, such as closed Alarm Shut-off Valve.

**W**hen a minor pressure surges occurs, slow as well as small transient increases in water supply pressure may continue to be built up in the system (via the Bypass Check Valve) without opening the Clapper. A transient surge in supply pressure that is sufficient to only momentarily open the Clapper will not cause a false alarm, and a portion of the increase in pressure will be trapped within the system, thus reducing the possibility of another opening. Any water in the alarm line is automatically drained, further reducing the possibility of a false alarm due to a successive transient surge in supply pressure.

#### **OPERATION WITH AN INSTALLED RETARD CHAMBER**

**W**hen the optional Retard Chamber is used, a surge of water, greater than what the bypass line can handle, will lift the clapper. Then water will enter the intermediate chamber through the holes in the Seat Ring, and it will fill the Retard Chamber. The water then drains from the

#### **DESIGN CRITERIA**

**F**or the installation, consideration must be given to the disposal of the large quantities of water that may be associated with draining the system or performing a flow test.

**V**ertically installed valves must have the flow going up. Horizontally installed valves must be positioned so that the drain connection points down.

**T**he sprinkler system designer must be aware that the configuration of the piping network and its tendency to trap pockets of air (such as in the case of a peaked-roof girded system) can affect the performance of the alarm system. Although a slight amount of trapped air is desirable to prevent significant pressure increases due to thermally induced expansion of the water, a large quantity of trapped air in a system may result in the possibility of an intermittent alarm.

**T**he possibility of an intermittent alarm condition is a consequence of the fact that the flow out of the system through the test valve or a single sprinkler is very small relative to the flow that can be passed through the valve. This difference increases with valve size. If the system were free of trapped air, flow in would equal flow out and the Clapper would always stabilize at some open position (as needed to accommodate the required flow). With trapped air in the system, however, the Clapper first opens wider since the system initially demands greater flow until the air pockets are compressed (back to nearly the supply pressure), and then it will tend to return closer to the Seat Ring. If the volume of the air pockets is excessive, flow into the system can be momentarily reduced to nearly zero (once the air pockets are compressed) and the Clapper may close, causing flow to the alarms to be shutoff.

Retard Chamber through a Restricted Orifice.

**A** sustained flow of water, as in an open sprinkler, will lift the clapper. The Retarding Chamber will fill faster than water can drain through the Restricted Orifice. And the water will fill the Retard Chamber completely; these events activate the Water Motor Alarm and/or Alarm Pressure Switch for the electric alarm.

**O**nce the Clapper has closed, sufficient water must flow out of the system before the Clapper will again open. A repetition of the above described condition is termed an intermittent alarm.

**U**sing a vent (which can also serve as an end-of-line Inspector's Test Connection) piped from the top of a cross main or end of a branch line at the point most remote from the alarm valve, and filling the system slowly in accordance with the steps described in the **Service Setting** section, can prevent an excessive amount of air from being trapped.

### INSTALLATION

#### WARNING

**Model NX009 Alarm Check Valves** described herein must be installed and maintained in compliance with this document, as well as with the applicable standards of the NFPA, in addition to the standards of any other authorities having jurisdictions. Failure to do so may impair the integrity of these devices.

**The owner is responsible for maintaining their fire protection system and devices in proper operating condition. The installing contractor or manufacturer should be contacted relative to any questions.**

**STEP 1** Verify that the appropriate trim chart and technical data for the Alarm Check Valve and associated equipment are available.

#### NOTES

**For proper operation, Model NX009 Alarm Check Valve must be trimmed in accordance with this data sheet for use on systems with water working pressure up to 175PSI / 1.2 MPa (12 bar). Failure to follow this installation instruction may prevent the device from functioning properly as well as void listings/approvals, and the manufacturer's warranties.**

**Model NX009 Alarm Check Valve must be installed in an area not subject to freezing temperatures or physical damage. Wet pipe sprinkler systems must be maintained at a minimum temperature of 40°F/4°C. When corrosive atmospheres and/or contaminated water supplies are present, it is the owner's responsibility to verify compatibility with the NX009 Alarm Check Valve, trim and associated equipment.**

**STEP 2** Prior to the actual installing the valve; thoroughly flush the water supply piping to verify that no foreign matter is present.

**STEP 3** Unpack the valve and remove all plastic thread protectors from the opening of the valve. Inspect the valve Clapper to ensure freedom of movement.

**STEP 4** Install the valve in the system so that the direction of water flow is the same as that indicated by the flow direction arrow on the

valve body. **MODEL NX009 ALARM CHECK VALVE MUST BE INSTALLED IN THE VERTICAL POSITION WITH DIRECTION OF FLOW UP.** Use the appropriate gaskets, bolts and/or couplings. Tighten all flange mounting fasteners uniformly as per piping standard.

#### NOTES

**The Alarm Check Valves must be installed in areas that are accessible and easily visible.**

**STEP 5** Install the trim in accordance with the instructions given in this data sheet. Apply a small amount of thread sealant or tape to external threads of all pipe connections required, sparingly to external threads only. **TAKE CARE NOT TO ALLOW ANY COMPOUND, TAPE OR OTHER FOREIGN MATTER INSIDE ANY NIPPLES OR OPENINGS OF THE VALVE OR TRIM COMPONENTS.**

#### NOTES

**It is recommended that provisions be made for viewing the alarm line drain water either by using an open type drain or by locating the main drain outlet in an easily visible area.**

**Suitable provision must be made for disposal of alarm line and system drainage water. Drainage water must be directed so that it will not cause damage or result in dangerous conditions.**

**Assure that all equipments (valves and trims) are adequately heated and protected to prevent freezing and physical damage.**

**Care must be taken when installing in the trim to be certain that they are located with the arrow on the body pointing in the proper direction. The draining pipes must be installed with direction of flow down.**

**STEP 6** Unused alarm connections should be plugged.

**STEP 7** Optional accessories (Retard Chamber, Water Motor Alarm, Alarm Pressure Switch, etc.) may be connected in accordance with the installation instructions accompanying the equipment. Upon completion of the system side of the installation, the system should be ready for pressurization.

**STEP 8** If a Water Motor Alarm is **NOT** to be used, the Alarm Vent Trim must be installed,



see Figure 6.

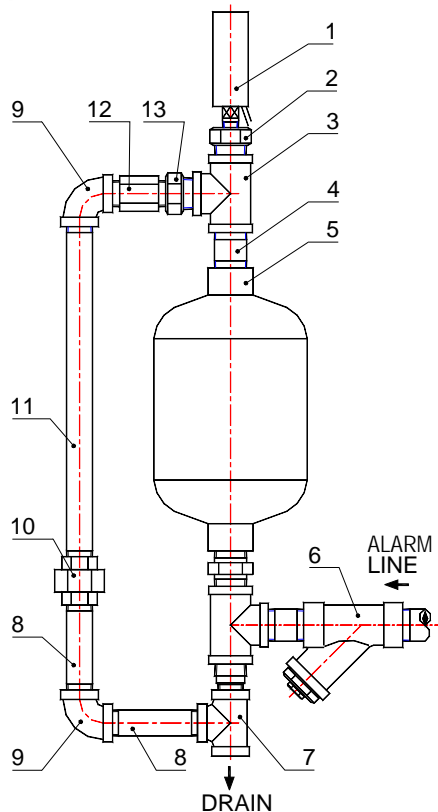

Ordered separately when  
Water Motor Alarm is not installed.

Figure 6: Alarm Vent Trim

No.	Description	Qty.	Remarks
1	Alarm Pressure Switch	1	Type PS75
2	Bushing 3/4"X1/4"	1	
3	Tee 3/4"	1	
4	Nipple 3/4"X2" (50)	1	
5	Retard Chamber Assembly	1	Optional, Ordered For Variable Pressure Systems, NX015
6	Strainer 3/4"	1	Type F1191Y
7	Tee 1/2"	1	
8	Nipple 1/2"X3 9/16" (90)	2	
9	90° Elbow 1/2"	2	
10	Union 1/2"	1	
11	Nipple 1/2"X1 1/4" (298)	1	
12	Vent Fitting 3/32"	1	With 3/32" Restriction
13	Bushing 3/4"X1/2"	1	

**STEP 9** It is recommended that a vent connection (which may also be used as an end-of line Inspector's Test Connection), be piped from a cross main or branch line at the point most remote from the alarm valve. The

vent line should be connected to the top of a cross main or to the end of a branch line and be located at the highest level of a multi-level installation.

The vent connection can be used to bleed off excessive air from the system, and therefore, minimize the possibility of a false alarm due to a transient surge in supply pressure. The contraction/expansion associated with an excessive amount of trapped air could also cause the waterway Clapper to cycle open and shut during an inspector's test or during a discharge by a single sprinkler.

### SERVICE SETTING

When set the Model NX009 Alarm Check Valve system initially or after system operation due to a fire, please perform the following setting procedure.

**STEP 1** Verify that all drains are closed and that the system is free of leaks.

**STEP 2** Open the system test valve (the end-of-line Inspector's Test Connection) and any auxiliary vents provided to facilitate removal of air from the system to allow air to escape from the system while it is filling with water.

### NOTES

For proper operation of the wet system and to minimize false alarms, it is important to remove trapped air from the system when filling it with water. Air trapped in the system may also cause intermittent operation of the water motor alarm during a sustained flow of water (such as the flow required by an open sprinkler or the system test valve) (Ref. **Design Criteria** section).

Consider installation of auxiliary vents to facilitate venting. (Ref. Step 9 in **Installation** section).

**STEP 3** If desired, close the Alarm Shut-off Valve to prevent local alarms from operating while filling the system.

### NOTES

Alarms and electric panels controlled by an alarm pressure switch installed in the "Electric Alarm Panel" connection provided in the trim cannot be interrupted.

**STEP 4** Slowly open the water supply main control valve until the sound of flowing water just begins and then open the valve one more turn.

### **CAUTION**

Opening of water supply main control valve will result in water flow from an opening in the system.

### **NOTES**

Filling the system with water will result in operation of the associated alarms. Thus, notification must first be given to the owner and fire department, central station, or other signal station to which the alarms are connected.

**STEP 5** Allow the system to completely fill with water. Allow water to flow from the system test valve (the end-of-line Inspector's Test Connection), and any other open vents provided, until all air is exhausted from the system. The outlet has flowed full for at least 15 seconds. Then close the system test valve and all other open vents.

**STEP 6** Fully open the water supply main control valve.

**STEP 7** Open the system test valve (the end-of-line Inspector's Test Connection) or Alarm Test Valve, and verify that the system alarms operate.

### **NOTES**

*Notify the proper authorities and all personnel who may be affected that an alarm test is to be performed.*

**STEP 8** Close the system test valve (the end-of-line Inspector's Test Connection) or Alarm Test Valve.

**STEP 9** Verify that water ceases to flow from the alarm line drain. If water continues to flow, follow the corrective procedure described in the **Care and Maintenance** section.

### **NOTES**

*The Retard Chamber has a 1/8" (3 mm) diameter Restricted Orifice. Sufficient time must be allowed for drainage of the Retard Chamber and the piping to the Water Motor Alarm.*

**STEP 10** Verify that the flow of water out of the alarm line drain has stopped. Verify the pressure

gauge. The pressure gauge on the system side of the Alarm Check valve Clapper should indicate water pressure equal to or greater than the water pressure indicated on the gauge located on the supply side of the clapper. Open the Alarm Shut-off Valve. Verify and secure that all valves are in their normal operating position. Then the alarm check valve system is set and ready for service.

### **NOTES**

After placing a fire protection system in service, notify the proper authorities and advise those responsible for monitoring proprietary and/or central station alarm, notify those in the affected area that the system is in service.

## **CARE AND MAINTENANCE**

The following procedures, inspection and testing should be performed as indicated, in addition to any specific requirements of the NFPA. **ANY IMPAIRMENT MUST BE IMMEDIATELY CORRECTED.**

The owner is responsible for the inspection, testing, and maintenance of their fire protection system and devices in compliance with this document, as well as with the applicable standards of the NFPA, in addition to the standards of any authority having jurisdiction. The installing contractor or manufacturer should be contacted relative to any questions.

It is recommended that automatic sprinkler systems be inspected, tested, and maintained by a qualified Inspection Service.

It is imperative that the alarm check valve system be maintained on a regular basis. The frequency of the maintenance may vary due to contaminated water supplies, and corrosive water supplies, and corrosive atmospheres. For minimum maintenance requirements, refer to the NFPA that describes care and maintenance of sprinkler systems. In addition, the Authority Having Jurisdiction may have additional inspection, testing and maintenance requirements that must be followed.

### **NOTES**

*Any system maintenance will result in operation of the associated alarm or eliminate*

the fire-protection capabilities of that system. Thus, notification must first be given to the owner and fire department, central station, or other signal station to which the system are connected. Consideration should be given to employment of a fire patrol in the affected areas.

**Before closing a fire protection system main control valve for maintenance work on the fire protection systems that it controls, permission to shut down the affected fire protection systems must first be obtained from the proper authorities.**

### **MONTHLY INSPECTION: VISUAL EXTERNAL CHECK-UP**

It is recommended that the following inspections be performed monthly by a qualified Inspection Service.

**STEP 1** Verify that pressure gauges indicate normal water supply pressures. It is normal for the gauge on the system side of the clapper to register a higher pressure than the gauge on the supply side of the clapper because pressure surges are trapped above the clapper.

**STEP 2** Check for signs of mechanical damage and/or corrosive activity. If detected, perform maintenance as required or, if necessary, replace the device.

**STEP 3** Verify that valve and trim are adequately heated and protected from freezing and physical damage.

**STEP 4** Verify that there is no unwanted leakage from the restricted drain of the Retard Chamber when equipped with variable pressure trim. It is normal for drainage to occur during pressure surges that exceed the capacity allowed through the bypass line trim.

**STEP 5** Verify that the water supply main control valve is open, and that all valves are in their normal operating position and appropriately secured.

### **QUARTERLY INSPECTION: WATER FLOW ALARM TEST**

It is recommended that the following checkup of **Water Flow Alarm Test** be performed quarterly by a qualified Inspection Service.

**STEP 1** Notify the proper authorities and all personnel who may be affected when the test is to be performed.

**STEP 2** Open the system test valve (the end-of-line Inspector's Test Connection) and verify that the system alarms operate in accordance with the requirements of the authority having jurisdiction. If freezing weather or other conditions prohibits use of the system test valve, open the Alarm Test Valve in the alarm check valve trim.

Verify that the local Water Motor Alarm should be audible. Verify that electric Alarm Pressure Switches should activate properly and within the elapsed time required by the authority having jurisdiction. Verify that electric local alarms should be audible. Verify that remote station alarm signals were received.

### **NOTES**

*Use of the Alarm Test Valve allows testing of alarms without reducing the system pressure.*

*When using the system test valve (the end-of-line Inspector's Test Connection) for the Water Flow Alarm Test, intermittent operation of the water motor alarm may indicate air is trapped in the system.*

**STEP 3** Verify that water is flowing out of the alarm line drain at a rate consistent with the 1/8" (3 mm) diameter drain Restricted Orifice in the Retard Chamber.

**STEP 4** Close the system test valve (the end-of-line Inspector's Test Connection) or Alarm Test Valve. Verify that water ceases to flow from the alarm line drain. Verify all local alarms stop sounding and electric panels reset. Verify all remote station alarms reset.

**STEP 5** Clean the Strainer (located at the connection to the Water Motor Alarm, as applicable). Be sure to replace the strainer baskets and tighten the caps securely.

### **NOTES**

*Cleaning of the Strainers after each operation of the alarm is especially important in the case of water supplies (such as lakes and rivers) having a large quantity of suspended matter. A clogged alarm line can prevent operation of the alarm.*

**STEP 6** Verify that the Alarm Shut-off Valve in the alarm line is open, the Alarm Test Valve is closed, and all valves are in their normal operating position and appropriately secured.

**STEP 7** Notify all authorities responsible for monitoring the installation that the fire protection system has been returned to service.

### **QUARTERLY INSPECTION: MAIN DRAIN TEST**

It is recommended that the following inspections of **Main Drain Test** be performed quarterly by a qualified Inspection Service.

**STEP 1** Notify the proper authorities and all personnel who may be affected when the test is to be performed.

**STEP 2** Check first to see that adequate drainage is provided for full flow from Main Drain outlet.

**STEP 3** Record pressure reading from the water supply pressure gauge.

**STEP 4** Fully open the main drain located on the Alarm Check Valve. When a full flow is developed from the main drain, record the residual pressure from the water supply pressure gauge.

**STEP 5** Then slowly close the main drain.

**STEP 6** Compare test results with previous flow information, if deterioration of the water supply is detected, take appropriate steps to restore adequate water supply.

**STEP 7** Verify that normal water supply pressure has been restored, and that all alarm devices and valves are secured in normal operating position.

**STEP 8** Notify all authorities responsible for monitoring the installation that the fire protection system has been returned to service.

### **FIVE YEAR INSPECTION: INTERNAL INSPECTION**

It is recommended that the following inspections of **Internal Inspection** should be performed every five years by a qualified

Inspection Service, unless inspections and tests indicate more frequent internal inspections are required.

**STEP 1** Notify the proper authorities and all personnel who may be affected when the test is to be performed. Consideration should be given to employment of a fire patrol in the affected areas.

**STEP 2** Close the water supply main control valve, placing the system out of service.

**STEP 3** Open the main drain. If necessary, open the system test valve (the end-of-line Inspector's Test Connection) to vent and completely drain the system.

**STEP 4** Use appropriate wrench to loosen and remove the Cover Plate Bolt, and remove Cover/ Clapper assembly.

**STEP 5** Inspect the Seat Ring. Wipe away all debris (contaminants, dirt and mineral deposits). Clean any orifices in the Seat Ring that are restricted or plugged by debris. **DO NOT USE SOLVENTS OR ABRASIVES.**

**STEP 6** Inspect the Cover/Clapper assembly and Cover Plate Gasket. Test Clapper for freedom of movement. Renew or replace damaged or worn parts as required.

### **CAUTION**

*Never apply any lubricant to seats, gaskets or any internal operating parts of the valve. Petroleum-based grease or oil will damage rubber components and may prevent proper operation.*

**STEP 7** When Internal Inspection of the Alarm Check Valve is complete, reinstall Cover/Clapper Assembly.

**STEP 8** Place the wet system back in service, Refer to **Service Setting** section.

### **MAINTENANCE OPERATION: SPRINKLER SYSTEM DRAIN DOWN**

Draining the sprinkler system must be done in accordance with the following procedure:

**STEP 1** Close the water supply main control valve, if this has not already been done.

**STEP 2** Open the remote cross main or branch line vent connection (Ref. Step 9 in **Installation**

section).

**STEP 3** Open the Main Drain Valve. Check first to see that the drainage water discharge will not cause damage or result in dangerous conditions.

**STEP 4** Wait until the Supply Pressure Gauge reads zero pressure and the sound of draining water has stopped before performing any maintenance work on the fire protection system.

#### **MAINTENANCE OPERATION: REMOVE AND REINSTALL COVER/CLAPPER ASSEMBLY**

Removing and reinstall the Cover/Clapper Assembly must be done in accordance with the following operation:

**To remove the Clapper Seal:** Use the appropriate wrench to loosen and remove the Clapper Screw, and Clapper Seal Retainer. Remove the Clapper Seal for inspection. If the Clapper Seal shows signs of wear such as cracking, cuts or excessively deep grooves where the Seal contacts the Seat Ring, replace the Clapper Seal.

**To reinstall the Clapper Seal:** Place Clapper Seal over the center of the Clapper Seal Retainer. Position the Retainer (with Seal in place) against Clapper. Replace and tighten the Clapper Screw. **DO NOT OVERTIGHTEN.**

**To remove the Clapper and/or the Clapper Shaft:** Remove Clapper Bushing to free the Clapper Shaft for removal. Then the Clapper can be removed.

**To reinstall Cover/Clapper assembly** (the Cover Plate, the Clapper, the Clapper Bushing and the Clapper Shaft): Verify that the Clapper Seal and the Cover Plate Gasket are in position and that they are in good condition. Slide the Cover/Clapper assembly into the Alarm Check Valve so that the Clapper Seal contacts the Seal Ring. Adjust Clapper Bushing; insert the Clapper Shaft through the holes. Continue to push the Clapper Shaft through the holes of another Clapper Bushing, adjust Bushings in position. Replace the Cover Plate Bolt. Use the appropriate wrench to evenly cross-tighten all Bolts with a torque of 18 to 20 ft·lbs (24.4 to 27.1 N·m). **DO NOT OVER TIGHTEN.**

#### **MALFUNCTION CORRECTED: LEAKAGE**

#### **FROM ALARM DRAIN**

Follow the steps indicated below until water ceases to flow from the alarm line drain. Check for the discontinuation of the leakage after each step is complete.

**STEP 1** Open the Main Drain Valve. Let the water flow for about 5 seconds and then close the Main Drain Valve. This should flush any loose debris that may have become trapped between the Clapper and the Seat Ring or in the seating area of the Drain Valve.

**STEP 2** Repeat Step 1 if the rate of continued flow out of the drain was noticeably reduced.

**STEP 3** Open the Alarm Test Valve and allow water to flow for about 5 seconds before re-closing the valve. This should flush any loose debris that may have become trapped in the seating area of the Alarm Test Valve.

**STEP 4** Repeat Step 3 if the rate of continued flow out of the drain was noticeably reduced.

**STEP 5** Determine whether the water is flowing from the alarm port or past the Alarm Test Valve. If the leakage is past the Alarm Test Valve, close the water supply main control valve, and then repair or replace the Alarm Test Valve as necessary.

**STEP 6** If it appears that the leakage noted in Step 5 is from the alarm port, drain the system. After the system has been drained, remove the Cover/Clapper Assembly.

**STEP 7** Using a light, check for and remove any debris that may have become lodged within the Seat Ring groove. Inspect the Seat Ring seat for any damage. If the Seat Ring has become dented across the seat then the Alarm Check Valve will have to be replaced. It is impractical to re-face a Seat Ring in the field.

**STEP 8** Check for and remove any debris that may have become lodged in the Clapper. If a minor imperfection remains in the Clapper, then turn it over after thoroughly cleaning both surfaces with a clean cloth. Replace the Clapper if necessary. Be sure to securely re-tighten the Clapper Screw for the Clapper Seal.

**STEP 9** Replace the Cover/Clapper Assembly. Return the Alarm Check Valve to operation in accordance with the steps described in the **Service Setting** section.

#### **MALFUNCTION CORRECTED: CLOGGED**

### ALARM LINE DRAIN

If water either does not flow or only dribbles out of the alarm line drain during an alarm test, then it is likely that the Restricted Orifice has become clogged.

### NOTES

**A** clogged alarm line drain will increase the possibility of a false alarm in the case of a variable pressure system.

**R**emove the Drain Restriction (in the Retard Chamber) and clean it by back flushing. Reinstall the Drain Restriction in the Retard Chamber and reassemble the alarm line.

### MALFUNCTION CORRECTED: LOSS OF EXCESS SYSTEM PRESSURE

In the case of a variable pressure system, the System Pressure Gauge should normally indicate a pressure greater than that shown by the Supply Pressure Gauge. Also, the value should be close to that of the peak supply pressure that has occurred after the system was placed in service.

### NOTES

**L**oss of excess system pressure will increase the possibility of a false alarm in the case of a variable pressure system.

**F**ollow the procedure indicated below to correct a loss of excess system pressure condition.

**STEP 1** Check for signs of continued leakage from the alarm line drain. If rust stains and/or water deposits indicate that continued leakage has been taking place, take corrective action according to the **Malfunction Corrected: Leakage From Alarm Drain** in **Care and Maintenance** section.

**STEP 2** If there is no signs of continued leakage from the alarm line drain, close the water supply main control valve, slowly open the union in the bypass line. Check for leakage past the Bypass Check Valve. If there is leakage, debris may have become lodged between its clapper and seat. Drain the system in accordance with the prescribed procedure and then clean or replace the Bypass Check Valve as required. Then reassemble the bypass line, and return the fire protection system.

**STEP 3** If there are no signs of leakage past

either the Alarm Check Valve Clapper or the Bypass Check Valve, inspect the sprinkler system for leakage.

### MALFUNCTION CORRECTED: EXCESS PRESSURE DUE TO THERMAL EXPANSION

**W**et pipe sprinkler systems subject to ambient temperatures in excess of 100°F/38°C can cause significant increases in system pressure due to the thermal expansion of the water. In particular, a gridded wet-pipe system with a relatively small air pocket and no relief valve can be subjected to an increase of more than 100 psi (6.9 bar), due to an increase in ambient temperature of about 50°F/28°C.

**A**s necessary, install a pressure relief valve, in accordance with the requirements of the authority having jurisdiction, to automatically relieve the excess pressure that could otherwise be created in wet-pipe systems that are exposed to significant increases in ambient temperature.

### MALFUNCTION CORRECTED: FALSE ALARMS

If repeated false alarms occur in a variable pressure system:

**STEP 1** Check for and correct the cause of continued leakage out the alarm line drain.

**STEP 2** Check for and clean a clogged alarm line drain.

**STEP 3** Check for and correct the cause of a loss in excess system pressure.

**STEP 4** Drain the sprinkler system and refill it in accordance with the steps described in the **Service Setting** section.

### MALFUNCTION CORRECTED: INTERMITTENT ALARMS

If the Pressure Alarm Switch gives a steady signal, but the Water Motor Alarm generates an intermittent alarm, check for binding in the Water Motor Alarm drive shaft.

If the Water Motor Alarm and/or the Pressure Alarm Switch provide an intermittent alarm, it is likely the consequence of an excessive amount of air being trapped within the sprinkler system. Drain down the sprinkler system and refill it in

accordance with the steps described in the **Service Setting** section.

**A** discontinuance of an alarm may also be caused by the Clapper closing due to a sudden drop in supply pressure or the shut-off of a pump in the supply line. These types of problems can only be corrected by maintaining a steady supply pressure.

### ORDERING PROCEDURE

**A** Product Symbol Number (PSN) shall be specified when ordering the products.

**C**ontact your local distributor for availability.

### STANDARD ORDER NX009 VALVES:

Standard NX009 Alarm Check Valve Specify: (specify size inch) Model NX009 Alarm Check Valve with (specify connection style), PSN (specify as follows).

**PSN 0111 1** X<sub>1</sub> X<sub>2</sub> **0**

X <sub>1</sub>	Alarm Check Valve Size
4	100
6	150
X <sub>2</sub>	Alarm Check Valve Connection Style
3	Flange X Flange
7	Groove X Groove

### STANDARD ORDER NX009 VALVE TRIM:

Standard NX009 Alarm Check Valve Trim Specify: Vertical, Opened Drain Galvanized Trim for (specify size inch) (specify connection style) Model NX009 Alarm Check Valve, PSN (specify as follows).

**PSN 0115 1** X<sub>1</sub> X<sub>2</sub> **1**

X <sub>1</sub>	Alarm Check Valve Size
4	100
6	150

X <sub>2</sub>	Alarm Check Valve Connection Style
3	Flange X Flange
7	Groove X Groove

### ACCESSORIES:

Order the following accessories, as applicable:  
Model NX015 Retard Chamber (required for variable pressure water supply conditions) with NPT connection style:

..... **PSN 0191 1100**

Model NX015 Retard Chamber (required for variable pressure water supply conditions) with ISO Thread connection style:

..... **PSN 0191 1200**

Model NX010 Water Motor Alarm (required for a mechanical water flow alarm) with NPT3/4 Alarm Line Inlet and NPT1 Drain Outlet:

..... **PSN 0121 1100**

Model NX010 Water Motor Alarm (required for a mechanical water flow alarm) with Rc3/4 Alarm Line Inlet and Rc1 Drain Outlet:

..... **PSN 0121 1200**

### CONVERSION TABLE

Name of Unit	Unit Symbol	Conversion Factor
Millimeter	mm	1 in.=25.4 mm
Square meter	m <sup>2</sup>	1 ft <sup>2</sup> =0.0929 m <sup>2</sup>
Liter	L	1 gal=3.785 L
Cubic decimeter	dm <sup>3</sup>	1 gal=3.785 dm <sup>3</sup>
Cubic meter	m <sup>3</sup>	1 ft <sup>3</sup> =0.0283 m <sup>3</sup>
Kilogram	kg	1 lb=16 ozs.=0.4536 kg
Kilograms per cubic meter	Kg/m <sup>3</sup>	1 lb/ft <sup>3</sup> =16.0183kg/m <sup>3</sup>
Pascal	Pa	1 psi=6895 Pa
Bar	bar	1 psi=0.0689 bar
Newton meter	N·m	1 ft·lbs=1.355 N·m

## ! WARNING



This product must be installed by an experienced, trained installer, in accordance with the instructions provided with each valve. These instructions contain important information. Failure to follow these instructions may result in serious personal injury, property damage, or valve leakage. We reserve the right to change product specifications, designs and standard equipment without notice and without incurring obligations. If you have any questions about the safe installation and use of this device, contact Smoothflo Australia